

□ Nomenclature of End Mill

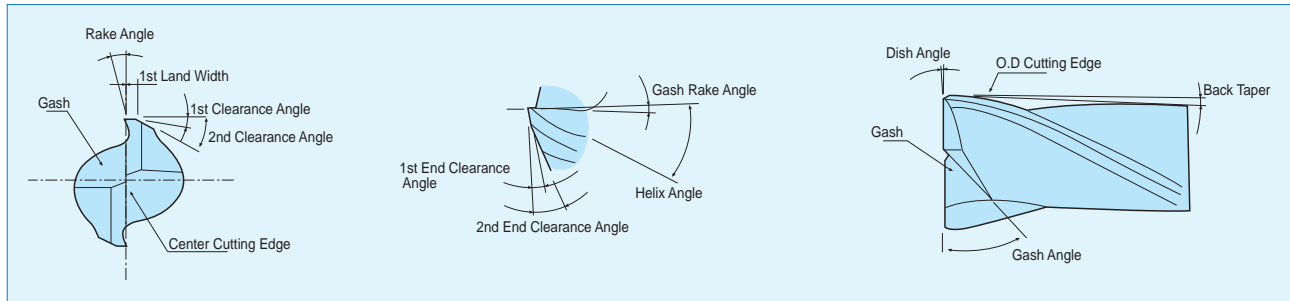

□ Application range of Grade

WORKPIECE	GRADE
Carbon Steel, Alloy Steel, Tool Steel, Metal Mold Steel	* Micro Grain Carbide * P30
Cast Iron, Ductile	* Micro Grain Carbide * K10-K20
Heat Treatment Steel(HRc 40-60)	* Ultrafinest Carbide
Aluminium, Nonferrous Material	* Micro Grain Carbide * K10

□ Formula of End Milling





1) Cutting Speed $V = \frac{\pi \times D \times N}{1000}$ (m/min)	V : Cutting Speed (m/min) D : Diameter of End Mill (mm) N : End Mill revolution (RPM)
2) Feed per tooth $f_z = \frac{F}{Z \times N}$ (mm/tooth)	fz : Feed per tooth (mm/tooth) Z : No. of teeth N : End Mill revolution (RPM)
3) Table Feed rate $F = f_z \times Z \times N$	F : Feed rate (mm/min) fz : Feed per tooth (mm/tooth) Z : No. of teeth N : End Mill revolution (RPM)
4) Cutting Time $T_c = \frac{L}{F}$	Tc: Cutting Time (min) F : Table feed rate (mm/ min) L : Length of cut (workpiece Length+Diameter of Endmill+ α)

▣ For Regrinding

1. Regrinding range

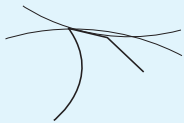
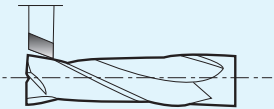
APPLICATION RANGE	CUTTER Dia.	AMOUNT OF FLANK WEAR
Finish Machining	~ $\varnothing 10$	0.05 ~ 0.1
	$\varnothing 11 \sim \varnothing 30$	0.1 ~ 0.25
	$\varnothing 31 \sim \varnothing 50$	0.2 ~ 0.35
Rough Machining	~ $\varnothing 10$	0.08 ~ 0.15
	$\varnothing 11 \sim \varnothing 30$	0.15 ~ 0.35
	$\varnothing 31 \sim \varnothing 50$	0.3 ~ 0.45

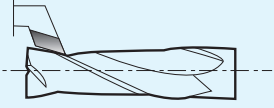
2. Regrinding Method of Relief

		<p>(1) Concave method</p> <ul style="list-style-type: none"> • In case when precise outer diameter dimension is required. • In case of aluminium machining.
		<p>(2) Flat method</p> <ul style="list-style-type: none"> • Excellent machinability - Applicable to ball end mill and taper end mill. • Secondary clearance angle work is required. - When Diameter is large.
		<p>(3) Eccentric method</p> <ul style="list-style-type: none"> • Excellent toughness and surface roughness. • Secondary clearance angle work is not required.

3. Honing

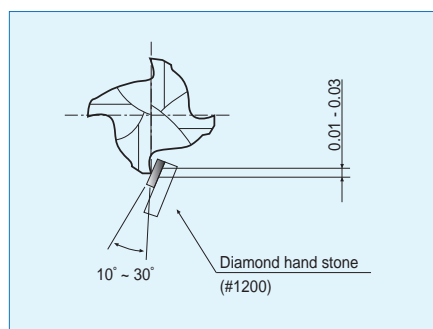

- 1) Recommend honing for machining mold metal and high hardness workpiece.
-The amount of honing shall be less than that of feed per blade.
- 2) When using end mill without honing, machine for 10 to 30 seconds at feed rate of less than 0.01 mm/blade and then machine at normal feed rate.
- 3) Honing is not required for machining aluminium and non-ferrous metal.

▣ Trouble Shooting for Endmilling

Problems		Cause	Solution	Cutting Conditions					Tool shape				Grade		The Others				
				Cutting Speed	Feed Rate	Depth of Cut	Coolant	Up & Down Cut	Relief Angle	Lead Angle	Cutting Length	Numbers of Teeth	Honing	Chip Pocket	Toughness	Hardness	Mechanical Rigidity	Mechanical Chattering	Workpiece Setting
Cutting edge breakage	Excessive wear on periphery	• Improper cutting conditions	▼	▲		⊙								▲					
	Chipping	• Improper cutting conditions • Generation of built-up edge • Improper tool grade		▼			▼	▼				⊙		▲			▼	▲	▼
	Breakage while cutting	• Improper cutting conditions • Excessive cutting load • Excessive overhang		▼	▼				▼							▲		▲	▼
Poor surface finish	• Generation of built-up edge		▲	▲		⊙			▲			⊙							
	• generation of chattering		▼			○	▼		▼						▲	⊙	▲	▼	
	• Surface Squareness			▼	▼		▲		▲	▼								▼	
Oversize or undersize	• Improper cutting conditions • Improper choice of endmill type		▲	▼			▼		▼	▲						▲	▼		▼
Poor chip control	• Excessive cutting rate • Improper chip Pocket • Improper cutting conditions			▼	▼						▼		▲						

▲ : Increase

▼ : Decrease

○ : Application

⊙ : Proper application

□ ZSTNB series

Work					Carbon Steels, Alloy Steels (180~250HB)		Pre-harden Steels (35~45HRC)		Hardened Steels (45~55HRC)		Hardened Steels (55~65HRC)	
Ratio to standard depth of cut					Depth of Cut X 100%		Depth of Cut X 80%		Depth of Cut X 65%		Depth of Cut X 60%	
R (mm)	Mill Dia (mm)	Neck Length (mm)	Neck Angle (°)	Depth of Cut (mm)	n (min ⁻¹)	Vf (mm/min)	n (min ⁻¹)	Vf (mm/min)	n (min ⁻¹)	Vf (mm/min)	n (min ⁻¹)	Vf (mm/min)
0.1	0.2	1	0.4	0.017	40,000	800	28,000	504	26,000	416	26,000	364
		1.5	0.4	0.009	40,000	800	28,000	504	26,000	416	26,000	364
		2	0.9	0.007	32,000	461	22,400	323	20,800	266	20,800	233
		2.5	0.9	0.004	26,000	333	18,200	204	16,900	189	16,900	162
0.15	0.3	2	0.4	0.025	40,000	1,200	28,000	756	26,000	624	26,000	546
		3	0.9	0.013	32,000	691	22,400	484	20,800	399	20,800	349
		4	0.9	0.010	26,000	499	18,200	306	16,900	284	16,900	243
0.2	0.4	2	0.4	0.035	40,000	1,600	28,000	1,008	26,000	832	26,000	728
		3	0.4	0.020	40,000	1,600	28,000	1,008	26,000	832	26,000	728
		4	0.4	0.007	32,000	922	22,400	645	20,800	532	20,800	466
		4	0.9	0.009	32,000	922	22,400	645	20,800	532	20,800	466
		5	0.4	0.006	26,000	666	18,200	408	16,900	379	16,900	324
		5	0.9	0.007	26,000	666	18,200	408	16,900	379	16,900	324
0.25	0.5	4	0.4	0.040	40,000	2,000	28,000	1,260	26,000	1,040	26,000	910
		8	0.9	0.010	26,000	728	18,200	446	16,900	414	16,900	355
		12	0.9	0.005	22,400	627	15,680	384	14,560	357	14,560	306
0.27	0.54	2	0.4	0.050	40,000	2,160	28,000	1,361	26,000	1,123	26,000	983
		4	0.4	0.037	40,000	2,160	28,000	1,361	26,000	1,123	26,000	983
		5	0.4	0.031	40,000	1,512	28,000	1,176	26,000	1,040	26,000	832
		6	0.4	0.025	26,000	1,244	18,200	871	16,900	676	16,900	629
		6.5	0.4	0.020	26,000	1,011	18,200	619	16,900	575	16,900	493
		7	0.4	0.015	26,000	899	18,200	585	16,900	543	16,900	465
0.3	0.6	2	0.4	0.055	40,000	2,400	28,000	1,512	26,000	1,248	26,000	1,092
		4	0.4	0.035	40,000	2,400	28,000	1,512	26,000	1,248	26,000	1,092
		6	0.4	0.018	32,000	1,382	22,400	968	20,800	799	20,800	699
		6	0.9	0.020	32,000	1,382	22,400	968	20,800	799	20,800	699
		8	0.9	0.020	26,000	998	18,200	612	16,900	568	16,900	487
		10	0.4	0.013	26,000	874	18,200	535	16,900	497	16,900	426
		10	0.9	0.015	26,000	874	18,200	535	16,900	497	16,900	426
		12	0.9	0.010	26,000	874	18,200	535	16,900	497	16,900	426
		15	0.4	0.005	22,400	753	15,680	461	14,560	367	14,560	367
		15	0.9	0.006	22,400	753	15,680	461	14,560	367	14,560	367

▣ ZSTNB series

Work					Carbon Steels, Alloy Steels (180~250HB)		Pre-harden Steels (35~45HRC)		Hardened Steels (45~55HRC)		Hardened Steels (55~65HRC)	
Ratio to standard depth of cut					Depth of Cut X 100%		Depth of Cut X 80%		Depth of Cut X 65%		Depth of Cut X 60%	
R (mm)	Mill Dia (mm)	Neck Length (mm)	Neck Angle (°)	Depth of Cut (mm)	n (min ⁻¹)	Vf (mm/min)	n (min ⁻¹)	Vf (mm/min)	n (min ⁻¹)	Vf (mm/min)	n (min ⁻¹)	Vf (mm/min)
0.4	0.8	4	0.4	0.062	32,000	2,560	22,400	1,613	20,800	1,331	20,800	1,165
		6	0.4	0.045	32,000	2,560	22,400	1,613	20,800	1,331	20,800	1,165
		8	0.9	0.026	25,600	1,475	17,920	1,032	16,640	852	16,640	745
		12	0.9	0.020	20,800	1,065	14,560	699	13,520	606	13,520	519
		16	0.9	0.018	20,800	932	14,560	612	13,520	530	13,520	454
0.45	0.9	4	0.4	0.063	28,300	2,547	19,810	1,605	18,395	1,324	18,395	1,159
		8	0.4	0.050	28,300	2,547	19,810	1,605	18,395	1,324	18,395	1,159
		12	0.4	0.037	18,400	1,325	12,880	811	11,960	753	11,960	646
		16	0.4	0.024	18,400	1,325	12,880	811	11,960	753	11,960	646
		18	0.4	0.018	18,400	1,325	12,880	811	11,960	753	11,960	646
		20	0.4	0.015	15,850	1,141	11,095	699	10,303	649	10,303	556
		22	0.4	0.012	15,850	1,141	11,095	699	10,303	649	10,303	556
		24	0.4	0.009	14,150	1,019	9,905	624	9,198	579	9,198	497
0.5	1	6	0.4	0.055	25,600	2,560	17,920	1,613	16,640	1,331	16,640	1,165
		8	0.4	0.055	25,600	2,560	17,920	1,613	16,640	1,331	16,640	1,165
		10	0.4	0.032	20,800	1,872	14,560	1,310	13,520	1,082	13,520	946
		10	0.9	0.035	20,800	1,872	14,560	1,310	13,520	1,082	13,520	946
		15	0.9	0.028	16,640	1,331	11,648	874	10,816	757	10,816	649
		20	0.4	0.018	16,640	1,331	11,648	874	10,816	757	10,816	649
		20	0.9	0.020	16,640	1,331	11,648	874	10,816	757	10,816	649
		25	0.9	0.017	14,560	1,165	10,192	764	9,464	662	9,464	568
		30	0.4	0.015	12,480	874	8,736	568	8,112	487	8,112	406
		30	0.9	0.017	12,480	874	8,736	568	8,112	487	8,112	406
		35	0.9	0.010	10,400	728	7,280	473	6,760	406	6,760	338
		40	0.9	0.009	10,000	700	7,000	455	6,500	390	6,500	325
		50	0.9	0.007	9,500	665	6,650	432	6,175	371	6,175	309
		60	0.9	0.005	9,000	630	6,300	410	5,850	351	5,850	293
		70	0.9	0.003	8,500	595	5,950	387	5,525	332	5,525	276
0.75	1.5	8	0.4	0.070	16,960	2,544	11,872	1,603	11,024	1,323	11,024	1,158
		10	0.4	0.070	16,960	2,544	11,872	1,603	11,024	1,323	11,024	1,158
		12	0.4	0.070	16,960	2,544	11,872	1,603	11,024	1,323	11,024	1,158
		15	0.9	0.045	13,568	1,832	9,498	1,282	8,819	1,058	8,819	926
		20	0.9	0.040	11,024	1,323	7,717	810	7,166	752	7,166	645
		30	0.9	0.028	11,024	1,323	7,717	810	7,166	752	7,166	645

□ ZSTNB series

Work					Carbon Steels, Alloy Steels (180~250HB)		Pre-hardened Steels (35~45HRC)		Hardened Steels (45~55HRC)		Hardened Steels (55~65HRC)	
Ratio to standard depth of cut					Depth of Cut X 100%		Depth of Cut X 80%		Depth of Cut X 65%		Depth of Cut X 60%	
R (mm)	Mill Dia (mm)	Neck Length (mm)	Neck Angle (°)	Depth of Cut (mm)	n (min ⁻¹)	Vf (mm/min)	n (min ⁻¹)	Vf (mm/min)	n (min ⁻¹)	Vf (mm/min)	n (min ⁻¹)	Vf (mm/min)
0.9	1.8	4	0.4	0.120	14,200	2,556	9,940	1,610	9,230	1,329	9,230	1,163
		8	0.4	0.100	14,200	2,556	9,940	1,610	9,230	1,329	9,230	1,163
		12	0.4	0.080	14,200	2,556	9,940	1,610	9,230	1,329	9,230	1,163
		16	0.4	0.071	14,200	2,556	9,940	1,610	9,230	1,329	9,230	1,163
		20	0.4	0.062	9,230	1,329	6,461	814	6,000	756	6,000	648
		24	0.4	0.053	9,230	1,329	6,461	814	6,000	756	6,000	648
		28	0.4	0.044	9,230	1,329	6,461	814	6,000	756	6,000	648
		32	0.4	0.036	9,230	1,329	6,461	814	6,000	756	6,000	648
		36	0.4	0.028	9,230	1,329	6,461	814	6,000	756	6,000	648
		38	0.4	0.020	8,000	1,152	5,600	706	5,200	655	5,200	562
		40	0.4	0.015	8,000	1,152	5,600	706	5,200	655	5,200	562
1	2	8	0.4	0.150	15,200	3,040	10,640	1,915	9,880	1,581	9,880	1,383
		12	0.4	0.090	15,200	3,040	10,640	1,915	9,880	1,581	9,880	1,383
		16	0.4	0.090	15,200	3,040	10,640	1,915	9,880	1,581	9,880	1,383
		20	0.4	0.060	12,160	2,189	8,512	1,532	7,904	1,265	7,904	1,107
		20	0.9	0.070	12,160	2,189	8,512	1,532	7,904	1,265	7,904	1,107
		25	0.9	0.070	9,880	1,581	6,916	968	6,442	899	6,422	771
		30	0.4	0.040	9,880	1,581	6,916	968	6,442	899	6,422	771
		30	0.9	0.045	9,880	1,581	6,916	968	6,442	899	6,422	771
		35	0.9	0.045	9,880	1,581	6,916	968	6,442	899	6,422	771
		40	0.4	0.030	9,880	1,581	6,916	968	6,442	899	6,422	771
		40	0.9	0.035	9,880	1,581	6,916	968	6,442	899	6,422	771
		50	0.9	0.170	8,512	1,192	5,958	775	5,533	664	5,533	553
		60	0.9	0.009	7,235	1,013	5,065	658	4,703	564	4,703	470
70	0.9	0.005	6,150	861	4,305	560	3,997	480	3,997	400		
1.5	3	8	0.4	0.320	12,720	3,816	8,904	2,404	8,268	1,984	8,268	1,736
		16	0.4	0.220	12,720	3,816	8,904	2,404	8,268	1,984	8,268	1,736
		20	0.4	0.150	12,720	3,434	8,904	2,137	8,268	1,736	8,268	1,488
		30	0.4	0.080	10,176	2,748	7,123	1,496	6,614	1,389	6,614	1,191
		30	0.9	0.090	10,176	2,748	7,123	1,496	6,614	1,389	6,614	1,191
		40	0.4	0.060	8,268	1,984	5,788	1,215	5,374	1,129	5,374	967
		40	0.9	0.070	8,268	1,984	5,788	1,215	5,374	1,129	5,374	967
		50	0.9	0.050	8,268	1,984	5,788	1,215	5,374	1,129	5,374	967
		60	0.9	0.030	7,123	1,710	4,986	1,047	4,630	972	4,630	833
		70	0.9	0.020	6,233	1,496	4,363	916	4,051	851	4,051	729

▣ ZSTNB series

Work					Carbon Steels, Alloy Steels (180~250HB)		Pre-hardened Steels (35~45HRC)		Hardened Steels (45~55HRC)		Hardened Steels (55~65HRC)	
Ratio to standard depth of cut					Depth of Cut X 100%		Depth of Cut X 80%		Depth of Cut X 65%		Depth of Cut X 60%	
R (mm)	Mill Dia (mm)	Neck Length (mm)	Neck Angle (°)	Depth of Cut (mm)	n (min ⁻¹)	Vf (mm/min)	n (min ⁻¹)	Vf (mm/min)	n (min ⁻¹)	Vf (mm/min)	n (min ⁻¹)	Vf (mm/min)
2	4	20	1	0.32	11,900	2,860	9,000	2,050	7,800	1,680	7,800	1,590
		30	1	0.23	11,900	2,570	9,000	1,850	7,800	1,520	7,800	1,430
		40	1	0.14	9,500	1,940	7,200	1,400	6,200	1,140	6,200	1,080
		50	1	0.11	7,800	1,590	5,800	1,120	5,000	920	5,000	870
		60	1	0.07	7,800	1,590	5,800	1,120	5,000	920	5,000	870
2.5	5	30	1	0.34	9,500	2,140	7,200	1,540	6,200	1,260	6,200	1,190
		40	1	0.25	9,500	2,140	7,200	1,540	6,200	1,260	6,200	1,190
		60	1	0.15	6,200	1,320	4,700	950	4,000	770	4,000	720
3	6	30	1	0.45	8,000	2,000	6,000	1,430	5,200	1,170	5,200	1,110
		40	1	0.40	8,000	1,800	6,000	1,280	5,200	1,050	5,200	990
		50	1	0.32	8,000	1,800	6,000	1,280	5,200	1,050	5,200	990
		60	1	0.22	6,400	1,360	4,800	970	4,100	780	4,100	740
		70	1	0.18	5,200	1,110	3,900	790	3,400	650	3,400	610
		80	1	0.14	5,200	1,110	3,900	790	3,400	650	3,400	610
4	8	50	1	0.50	6,000	1,460	4,500	1,040	3,900	850	3,900	810
		60	1	0.43	6,000	1,460	4,500	1,040	3,900	850	3,900	810
		70	1	0.33	6,000	1,460	4,500	1,040	3,900	850	3,900	810
		80	1	0.25	4,800	1,100	3,600	780	3,100	640	3,100	600
5	10	60	1	0.70	4,800	1,300	3,600	920	3,100	750	3,100	710
		75	1	0.50	4,800	1,300	3,600	920	3,100	750	3,100	710

- Please adjust the cutting depth index according to the cutting depth factors of above table.
- For Rib or Slotting machining process which are not easy for chip ejection, please reduce the cutting depth by 20~30% from the above cutting condition.
ex) ZSTNB2040-20-10, HRC 55, Rib processing
Cutting depth : 0.32(standard cutting depth) X 0.65 X 0.8 = 0.17mm
- In actual machining, the condition should be adjusted according to the machining shape, purpose and the machine type.
- If RPM of the machine is low, the feed rate should be low in the same ratio as RPM.

□ ZSTNR series

Work				Carbon Steels, Alloy Steels (180~250HB)		Pre-harden Steels (35~45HRC)		Hardened Steels (45~55HRC)		Hardened Steels (55~65HRC)	
Ratio to standard depth of cut				Depth of Cut X 100%		Depth of Cut X 80%		Depth of Cut X 65%		Depth of Cut X 60%	
Mill Dia (mm)	R (mm)	Neck Length (mm)	Depth of Cut (mm)	n (min ⁻¹)	Vf (mm/min)	n (min ⁻¹)	Vf (mm/min)	n (min ⁻¹)	Vf (mm/min)	n (min ⁻¹)	Vf (mm/min)
0.2	0.05	2	0.007	39,660	887	33,660	754	29,700	591	27,720	483
0.4	0.05	4	0.009	30,096	899	25,582	764	22,572	599	21,067	489
		5	0.007	26,752	710	22,739	528	20,064	466	18,726	373
	0.1	4	0.009	31,680	946	26,928	804	23,760	631	22,176	515
		5	0.007	28,160	747	23,936	556	21,120	490	19,712	392
0.5	0.1	5	0.013	30,413	1,090	25,851	753	22,810	562	21,289	453
		8	0.008	24,330	678	20,681	468	18,248	350	17,031	282
		10	0.007	18,248	509	15,511	351	13,686	262	12,773	211
0.6	0.1	12	0.010	20,377	791	17,320	546	15,282	408	14,264	329
		15	0.006	16,727	649	14,218	448	12,545	335	11,709	270
0.8	0.2	6	0.045	31,680	1,084	26,928	921	23,760	723	22,176	590
		12	0.020	28,160	943	23,936	695	21,120	613	19,712	490
1	0.2	8	0.040	28,512	1,463	24,235	1,244	21,384	976	19,958	797
		10	0.035	28,512	1,596	24,235	1,357	21,384	1,064	19,958	869
		15	0.028	25,344	1,261	21,542	938	19,008	828	17,741	662
		20	0.020	19,008	828	16,157	653	14,256	532	13,306	414
		25	0.017	15,840	690	13,464	544	11,880	443	11,088	345
		30	0.017	15,840	690	13,464	544	11,880	443	11,088	345
	0.3	35	0.010	15,840	690	13,464	544	11,880	443	11,088	345
		8	0.040	28,512	1,463	24,235	1,244	21,384	976	19,958	797
		15	0.028	25,344	1,261	21,542	938	19,008	828	17,741	662
		25	0.017	15,840	690	13,464	544	11,880	443	11,088	345
1.5	0.2	10	0.050	21,683	1,079	18,431	803	16,262	708	15,178	567
		15	0.045	19,712	981	16,755	730	14,784	644	13,798	515
		20	0.042	17,347	863	14,745	642	13,010	567	12,143	453
		25	0.032	14,784	644	12,566	508	11,088	414	10,349	322
	0.3	30	0.028	12,320	536	10,472	423	9,240	345	8,624	268
		10	0.050	21,683	1,079	18,431	803	16,262	708	15,178	567
		20	0.042	17,347	863	14,745	642	13,010	567	12,143	453
		25	0.032	14,784	644	12,566	508	11,088	414	10,349	322
		30	0.028	12,320	536	10,472	423	9,240	345	8,624	268

▣ ZSTNR series

Work				Carbon Steels, Alloy Steels (180~250HB)		Pre-harden Steels (35~45HRC)		Hardened Steels (45~55HRC)		Hardened Steels (55~65HRC)		
Ratio to standard depth of cut				Depth of Cut X 100%		Depth of Cut X 80%		Depth of Cut X 65%		Depth of Cut X 60%		
Mill Dia (mm)	R (mm)	Neck Length (mm)	Depth of Cut (mm)	n (min ⁻¹)	Vf (mm/min)	n (min ⁻¹)	Vf (mm/min)	n (min ⁻¹)	Vf (mm/min)	n (min ⁻¹)	Vf (mm/min)	
2	0.2	30	0.045	13,440	1,254	11,424	933	10,080	823	9,408	658	
		40	0.035	10,080	823	8,568	650	7,560	529	7,056	412	
		50	0.017	8,400	686	7,140	541	6,300	441	5,880	343	
	0.3	12	0.088	22,680	1,814	19,278	1,427	17,010	1,191	15,876	1,048	
		20	0.054	18,144	1,452	15,422	1,141	13,608	953	12,701	838	
		30	0.045	13,440	1,393	11,424	1,036	10,080	914	9,408	732	
		40	0.035	10,080	914	8,568	722	7,560	588	7,056	457	
		50	0.017	8,400	762	7,140	601	6,300	490	5,880	381	
	0.5	8	0.170	22,680	1,814	19,278	1,427	17,010	1,191	15,876	1,048	
		12	0.088	22,680	1,814	19,278	1,427	17,010	1,191	15,876	1,048	
		16	0.088	19,278	1,542	16,386	1,213	14,459	1,012	13,495	891	
		20	0.054	18,114	1,452	15,422	1,141	13,608	953	12,701	838	
		25	0.054	15,876	1,270	13,495	999	11,907	833	11,113	733	
		30	0.045	13,440	1,393	11,424	1,036	10,080	914	9,408	732	
		40	0.035	10,080	914	8,568	722	7,560	588	7,056	457	
	50	0.017	8,400	762	7,140	601	6,300	490	5,880	381		
	3	0.2	40	0.070	10,240	956	8,704	711	7,680	627	7,168	502
			50	0.050	7,680	627	6,528	495	5,760	403	5,376	314
			60	0.030	6,400	523	5,440	412	4,800	336	4,480	261
		0.3	40	0.070	10,240	1,062	8,704	790	7,680	697	7,168	557
			50	0.050	7,680	697	6,528	550	5,760	448	5,376	348
60			0.030	6,400	581	5,440	458	4,800	373	4,480	290	
0.5		40	0.070	10,240	1,062	8,704	790	7,680	697	7,168	557	
		50	0.050	7,680	697	6,528	550	5,760	448	5,376	348	
		60	0.030	6,400	581	5,440	458	4,800	373	4,480	290	

- Please adjust the cutting depth index according to the cutting depth factors of above table.
- In actual machining, the condition should be adjusted according to the machining shape, purpose and machine type.
- If RPM of the machine is low, the feed rate should be low in the same ratio as RPM.

□ ZSLNR series

Work				Carbon Steels, Alloy Steels (180~250HB)	Pre-hardened Steels (35~45HRC)	Hardened Steels (45~55HRC)	Hardened Steels (55~65HRC)					
Ratio to standard depth of cut				Depth of Cut X 100%	Depth of Cut X 80%	Depth of Cut X 65%	Depth of Cut X 60%					
Mill Dia (mm)	R (mm)	Neck Length (mm)	Depth of Cut (mm)	n (min ⁻¹)	Vf (mm/min)	n (min ⁻¹)	Vf (mm/min)	n (min ⁻¹)	Vf (mm/min)	n (min ⁻¹)	Vf (mm/min)	
0.2	0.05	0.5	0.020	50,000	258	50,000	205	50,000	180	50,000	160	
		1	0.014	50,000	258	50,000	205	50,000	180	50,000	160	
		1.5	0.008	50,000	240	45,900	202	45,900	170	45,900	153	
		2	0.008	42,000	202	36,700	176	36,700	162	36,700	147	
0.3	0.05	1	0.021	50,000	585	50,000	456	50,000	336	50,000	320	
		1.5	0.016	50,000	585	45,000	456	45,000	336	45,000	320	
		2	0.012	45,000	530	45,000	420	45,000	300	45,000	290	
		2.5	0.010	40,000	471	40,000	373	40,000	267	40,000	258	
		3	0.008	35,000	412	35,000	326	30,000	200	30,000	194	
0.4	0.05	1	0.025	50,000	580	50,000	461	40,000	320	36,000	270	
		1.5	0.020	50,000	580	50,000	461	40,000	320	36,000	270	
		2	0.016	45,000	520	45,000	410	36,000	290	34,000	240	
		2.5	0.015	40,500	480	40,500	370	33,400	270	30,600	220	
		3	0.014	40,000	410	40,000	330	32,800	240	25,600	200	
		3.5	0.012	36,000	380	36,000	300	29,400	200	22,920	180	
	0.1	0.1	4	0.008	30,000	320	30,000	250	21,600	160	19,200	150
			2	0.028	45,000	520	45,000	410	36,000	290	34,000	240
			3	0.016	40,000	410	40,000	330	32,800	240	25,600	200
			4	0.010	30,000	320	30,000	250	21,600	160	19,200	150
0.5	0.05	1	0.030	50,000	898	40,000	464	30,000	378	28,000	315	
		2	0.023	50,000	898	40,000	464	30,000	378	28,000	315	
		3	0.017	45,000	810	36,000	414	27,000	315	24,500	261	
		4	0.017	40,000	820	32,000	378	24,000	279	20,000	234	
		5	0.011	28,800	540	19,400	280	18,000	250	15,000	200	
		6	0.008	28,800	480	19,400	260	18,000	250	15,000	200	
	0.1	0.1	1	0.035	50,000	898	40,000	464	30,000	378	28,000	315
			2	0.030	50,000	898	40,000	464	30,000	378	28,000	315
			3	0.020	45,000	810	36,000	414	27,000	315	24,500	261
			4	0.020	40,000	720	32,000	378	24,000	279	20,000	234
			5	0.013	28,800	540	19,400	280	18,000	250	15,000	200
			6	0.013	28,800	480	19,400	260	18,000	250	15,000	200
0.6	0.1	2	0.035	50,000	1,159	37,830	600	28,200	390	23,000	320	
		4	0.024	40,000	830	27,800	440	23,600	280	21,000	230	
		6	0.015	24,000	490	18,000	300	17,800	240	15,000	210	
		8	0.013	24,000	466	18,000	285	17,800	228	15,000	200	
		10	0.009	24,000	451	18,000	276	17,800	221	15,000	193	

▣ ZSTNR series

Work				Carbon Steels, Alloy Steels (180~250HB)		Pre-hardened Steels (35~45HRC)		Hardened Steels (45~55HRC)		Hardened Steels (55~65HRC)		
Ratio to standard depth of cut				Depth of Cut X 100%		Depth of Cut X 80%		Depth of Cut X 65%		Depth of Cut X 60%		
Mill Dia (mm)	R (mm)	Neck Length (mm)	Depth of Cut (mm)	n (min ⁻¹)	Vf (mm/min)	n (min ⁻¹)	Vf (mm/min)	n (min ⁻¹)	Vf (mm/min)	n (min ⁻¹)	Vf (mm/min)	
0.8	0.1	4	0.032	48,000	1,102	28,000	518	20,000	320	20,000	288	
		6	0.019	38,700	800	25,000	461	18,000	288	18,000	256	
		8	0.015	29,025	600	20,000	369	16,200	259	16,200	230	
	0.2	12	0.012	29,025	570	20,000	350	16,200	246	16,200	219	
		4	0.056	48,000	1,102	28,000	518	20,000	320	20,000	288	
		6	0.032	38,700	800	25,000	461	18,000	288	18,000	256	
1	0.1	4	0.038	32,400	1,359	27,540	1,039	24,300	815	22,680	666	
		6	0.024	26,244	990	22,307	842	19,683	660	18,371	539	
		8	0.024	23,328	880	19,829	748	17,496	587	16,330	479	
		10	0.015	20,412	770	17,350	655	15,309	514	14,288	419	
		12	0.015	18,144	609	15,422	453	13,608	399	12,701	320	
		16	0.009	18,144	533	15,422	420	13,608	342	12,701	266	
		20	0.006	13,608	399	11,567	315	10,206	257	9,526	200	
	0.2	4	0.070	32,400	1,359	27,540	1,039	24,300	815	22,680	666	
		6	0.040	26,244	990	22,307	842	19,683	660	18,371	539	
		8	0.040	23,328	880	19,829	748	17,496	587	16,330	479	
		10	0.025	20,412	770	17,350	655	15,309	514	14,288	419	
		12	0.025	18,144	609	15,422	453	13,608	399	12,701	320	
		16	0.015	18,144	533	15,422	420	13,608	342	12,701	266	
		20	0.010	13,608	399	11,567	315	10,206	257	9,526	200	
	0.3	6	0.040	26,244	990	22,307	842	19,683	660	18,371	539	
		10	0.025	20,412	770	17,350	655	15,309	514	14,288	419	
		16	0.015	18,144	533	15,422	420	13,608	342	12,701	266	
		20	0.010	13,608	399	11,567	315	10,206	257	9,526	200	
	1.5	0.1	4	0.042	24,930	1,130	20,956	868	18,711	678	17,364	556
			8	0.036	22,680	1,027	19,278	873	17,010	685	15,876	559
			12	0.036	18,144	822	15,422	698	13,608	548	12,701	447
			15	0.023	14,112	568	11,995	423	10,584	373	9,878	298
			20	0.018	14,112	568	11,995	423	10,584	373	9,878	298
		0.2	4	0.070	24,930	1,130	20,956	868	18,711	678	17,364	556
8			0.060	22,680	1,027	19,278	873	17,010	685	15,876	559	
12			0.060	18,144	822	15,422	698	13,608	548	12,701	447	
15			0.038	14,112	568	11,995	423	10,584	373	9,878	298	
20			0.030	14,112	568	11,995	423	10,584	373	9,878	298	
0.3		8	0.060	22,680	1,027	19,278	873	17,010	685	15,876	559	
		15	0.038	14,112	568	11,995	423	10,584	373	9,878	298	
		20	0.030	14,112	568	11,995	423	10,584	373	9,878	298	

▣ ZSTNR series

Work				Carbon Steels, Alloy Steels (180~250HB)		Pre-harden Steels (35~45HRC)		Hardened Steels (45~55HRC)		Hardened Steels (55~65HRC)	
Ratio to standard depth of cut				Depth of Cut X 100%		Depth of Cut X 80%		Depth of Cut X 65%		Depth of Cut X 60%	
Mill Dia (mm)	R (mm)	Neck Length (mm)	Depth of Cut (mm)	n (min ⁻¹)	Vf (mm/min)	n (min ⁻¹)	Vf (mm/min)	n (min ⁻¹)	Vf (mm/min)	n (min ⁻¹)	Vf (mm/min)
2	0.2	6	0.080	20,790	1,635	17,672	1,389	15,593	981	14,553	801
		8	0.070	18,900	1,486	16,065	1,263	14,175	892	13,230	728
		12	0.040	15,309	1,083	13,013	921	11,482	722	10,716	590
		16	0.040	13,608	963	11,567	818	10,206	642	9,526	524
		20	0.035	11,907	843	10,121	716	8,930	562	8,335	459
		25	0.025	11,907	843	10,121	716	8,930	562	8,335	459
		30	0.017	11,312	800	9,615	680	8,484	534	7,918	436
	0.3	8	0.090	18,900	1,651	16,065	1,403	14,175	991	13,230	809
		16	0.060	13,608	1,070	11,567	909	10,206	713	9,526	583
		20	0.037	11,907	936	10,121	796	8,930	624	8,335	510
	0.5	6	0.017	20,709	1,635	17,672	1,389	15,593	981	14,553	801
		8	0.014	18,900	1,651	16,065	1,403	14,175	991	13,230	809
		12	0.080	15,309	1,204	13,013	1,023	11,482	802	10,716	655
		16	0.080	13,608	1,070	11,567	909	10,206	713	9,526	583
		20	0.050	11,907	936	10,121	796	8,930	624	8,335	510
		25	0.050	11,907	936	10,121	796	8,930	624	8,335	510
		30	0.030	11,312	889	9,615	756	8,484	593	7,918	484
	0.8	8	0.200	18,900	1,651	16,065	1,403	14,175	991	13,230	809
		16	0.100	13,608	1,070	11,567	909	10,206	713	9,526	583
		20	0.060	11,907	936	10,121	796	8,930	624	8,335	510
	3	0.2	8	0.090	14,400	1,415	12,240	1,203	10,800	849	10,080
12			0.070	14,400	1,415	12,240	1,203	10,800	849	10,080	693
16			0.050	14,400	1,415	12,240	1,203	10,800	849	10,080	693
20			0.050	11,664	1,146	9,914	974	8,748	764	8,165	624
30			0.040	9,072	1,146	7,711	974	6,804	764	6,350	624
35			0.035	9,072	1,146	7,711	974	6,804	764	6,350	624
0.3		8	0.130	14,400	1,572	12,240	1,337	10,800	943	10,080	771
		16	0.075	14,400	1,572	12,240	1,337	10,800	943	10,080	771
		20	0.075	11,664	1,274	9,914	1,083	8,748	849	8,165	693
		30	0.060	9,072	1,274	7,711	1,083	6,804	849	6,350	693
0.5		8	0.180	14,400	1,572	12,240	1,337	10,800	943	10,080	771
		12	0.130	14,400	1,572	12,240	1,337	10,800	943	10,080	771
		16	0.100	14,400	1,572	12,240	1,337	10,800	943	10,080	771
		20	0.100	11,664	1,274	9,914	1,083	8,748	849	8,165	693
		30	0.080	9,072	1,274	7,711	1,083	6,804	849	6,350	693
		35	0.065	9,072	1,274	7,711	1,083	6,804	849	6,350	693

- Please adjust the cutting depth index according to the cutting depth factors of above table.
- In actual machining, the condition should be adjusted according to the machining shape, purpose and machine type.
- If RPM of the machine is low, the feed rate should be low in the same ratio as RPM.

▣ ZS1(2)04, ZS204 series ▶ Side Cutting

MATERIAL	HARDENED STEELS		HARDENED STEELS		HARDENED STEELS		HARDENED STEELS		HARDENED STEELS	
HARDNESS	HRc 40~HRc 50		HRc 50~HRc 55		HRc 55~HRc 60		HRc 60~HRc 65		HRc 65~HRc 70	
DIAMETER(mm)	RPM	FEED	RPM	FEED	RPM	FEED	RPM	FEED	RPM	FEED
4	17200	1690	11440	1140	9360	700	7280	430	6170	310
6	13450	1820	8970	1230	6890	720	5460	450	4810	330
8	9100	1750	6760	1170	5200	670	4160	420	3640	310
10	8000	1630	5330	1090	4160	620	3320	400	2860	280
12	6830	1630	4550	1010	3450	580	2730	370	2420	260

RPM = rev. / min.
FEED = mm / min.

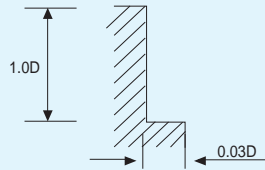

▣ ZSPM4...-.. series

MATERIAL	HARDENED STEELS									
HARDNESS	~HRc40		HRc 40 ~ HRc 50		HRc 50 ~ HRc 55		HRc 55 ~ HRc 60		HRc 60 ~ HRc 65	
D X R(mm)	RPM	FEED	RPM	FEED	RPM	FEED	RPM	FEED	RPM	FEED
3 X R0.5	9550	6500	6900	4150	4550	2750	2850	1150	1900	610
4 X R0.5	7950	7000	5750	4600	4000	3200	2550	1350	1750	700
6 X R0.5	5800	7650	4100	4900	2900	3500	1850	1850	1350	795
6 X R1.0	5800	7650	4100	4900	2900	3500	1850	1850	1350	795
8 X R1.0	4350	7650	3050	4900	2200	3500	1400	1850	995	795
8 X R2.0	4350	7650	3050	4900	2200	3500	1400	1850	995	795
10 X R1.0	3500	7650	2450	4900	1750	3500	1100	1850	795	795
10 X R2.0	3500	7650	2450	4900	1750	3500	1100	1850	795	795
12 X R2.0	2900	7650	2050	4900	1450	3500	925	1850	665	795
12 X R3.0	2900	7650	2050	4900	1450	3500	925	1850	665	795

RPM = rev. / min.
FEED = mm / min.

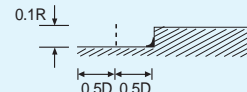
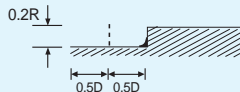

▣ ZSPM4...-.. series ▶ High Speed Cutting

MATERIAL HARDNESS	HARDENED STEELS									
	~HRc40		HRc 40 ~ HRc 50		HRc 50 ~ HRc 55		HRc 55 ~ HRc 60		HRc 60 ~ HRc 65	
D X R(mm)	RPM	FEED	RPM	FEED	RPM	FEED	RPM	FEED	RPM	FEED
3 X R0.5	22000	16000	17000	10000	12500	8000	9500	4600	6900	2500
4 X R0.5	17000	17500	13000	12000	11000	9200	8000	5500	5600	2900
6 X R0.5	13500	18500	10500	13800	9000	11000	6400	6400	4500	3600
6 X R1.0	13500	18500	10500	13800	9000	11000	6400	6400	4500	3600
8 X R1.0	10000	18500	8000	14000	6800	11000	4800	6700	3400	4100
8 X R2.0	10000	18500	8000	14000	6800	11000	4800	6700	3400	4100
10 X R1.0	8000	18500	6400	14000	5400	11000	3800	6800	2700	3800
10 X R2.0	8000	18500	6400	14000	5400	11000	3800	6800	2700	3800
12 X R2.0	6600	18500	5300	14000	4500	11000	3200	7000	2250	3600
12 X R3.0	6600	18500	5300	14000	4500	11000	3200	7000	2250	3600

RPM = rev. / min.
FEED = mm / min.

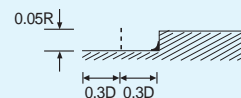
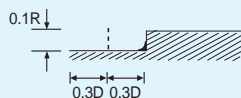

▣ DB702, DB712 series

MATERIAL HARDNESS	HARDENED STEELS HEAT RESISTANT STEELS		HARDENED STEELS		HARDENED STEELS		HARDENED STEELS		HARDENED STEELS		HARDENED STEELS	
	HRc 30~ HRc 40	HRc 40~ HRc 50	HRc 40~ HRc 50	HRc 50~ HRc 55	HRc 55~ HRc 60	HRc 55~ HRc 60	HRc 60~ HRc 65	HRc 60~ HRc 65	HRc 65~ HRc 70	HRc 65~ HRc 70	HRc 65~ HRc 70	HRc 65~ HRc 70
DIAMETER(mm)	RPM	FEED	RPM	FEED	RPM	FEED	RPM	FEED	RPM	FEED	RPM	FEED
0.2	50000	1200	50000	1050	45000	960	40000	770	35000	674	31500	570
0.3	50000	1500	50000	1350	45000	1200	40000	965	35000	840	31500	700
0.4	50000	1900	50000	1700	45000	1500	40000	1200	35000	1050	31500	890
0.5	50000	2400	50000	2100	45000	1900	40000	1500	35000	1300	31500	1100
0.6	50000	2900	50000	2500	45000	2200	40000	1800	35000	1600	31500	1400
0.8	50000	3900	50000	3300	45000	3000	40000	2400	35000	2100	31500	1800
1	50000	4800	50000	4200	45000	3800	40000	3000	35000	2600	35000	2300
1.5	50000	5400	48000	4500	43000	4000	37000	3100	33000	2700	29700	2300
2	49700	5700	47800	4800	40000	4000	35000	3150	32000	2800	28500	2300
3	33100	6000	31800	5300	26500	4000	23500	3150	21000	2800	19000	2300
4	24900	6000	23900	5300	20000	4000	17500	3150	16000	2800	14500	2300
5	18600	5800	17800	4900	15000	3750	13500	3050	11500	2550	10500	2100
6	13900	4850	13400	4100	11000	3100	10000	2500	8800	2150	8000	1750
8	11100	4200	10700	3500	9000	2700	8000	2150	7000	1850	6500	1550
10	9300	3700	8900	3100	7500	2400	6600	1900	5800	1650	5300	1380
12	6950	2950	6680	2500	5600	1900	5000	1550	4400	1250	4000	1050

RPM = rev. / min.
FEED = mm / min.

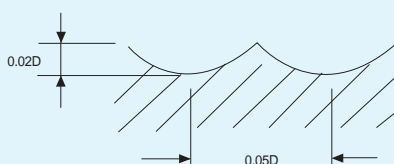

ZE702, ZE712 series ▶ Slotting

MATERIAL	HARDENED STEELS HEAT RESISTANT STEELS		HARDENED STEELS		HARDENED STEELS		HARDENED STEELS		HARDENED STEELS		HARDENED STEELS	
	HARDNESS		HARDNESS		HARDNESS		HARDNESS		HARDNESS		HARDNESS	
	HRc 30~ HRc 40		HRc 40~ HRc 50		HRc 50~ HRc 55		HRc 55~ HRc 60		HRc 60~ HRc 65		HRc 65~ HRc 70	
DIAMETER(mm)	RPM	FEED	RPM	FEED	RPM	FEED	RPM	FEED	RPM	FEED	RPM	FEED
0.2	50000	130	45000	115	40000	95	33000	60	33000	45	26400	30
0.3	50000	190	45000	140	40000	115	33000	70	25000	50	20000	35
0.4	50000	235	45000	180	40000	140	33000	90	25000	55	20000	40
0.5	50000	370	45000	280	40000	220	33000	140	25000	85	20000	60
0.6	50000	470	45000	360	40000	285	30000	160	25000	105	20000	75
0.8	50000	600	40000	440	30000	295	25000	185	19000	110	15200	80
0.9	49000	655	39000	520	27800	330	22700	205	17500	125	14000	90
1	48000	750	38000	570	25500	360	20500	215	16000	135	12500	85
2	33300	850	26000	680	17500	420	14500	260	11000	160	9500	115
3	21800	850	17300	680	11500	420	9500	260	7500	160	6400	115
4	16700	880	13200	700	8800	440	7200	270	5600	170	4750	118
5	15700	1000	12500	805	8300	500	6400	285	5100	180	4450	132
6	13100	950	10350	770	6900	480	5300	280	4200	180	3700	130
8	9880	930	7800	720	5200	445	4000	255	3200	165	2800	120
10	7800	850	6150	680	4100	415	3200	240	2550	155	2200	112
12	6650	850	5250	680	3500	415	2650	240	2100	155	1860	112
16	4900	730	3900	580	2600	365	2000	210	1600	135	1400	95
20	3900	660	3100	525	2050	335	1600	195	1300	125	1100	85

RPM = rev. / min.
FEED = mm / min.

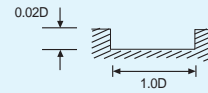
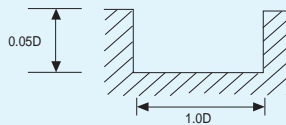

ZE702, ZE712 series ▶ Side Cutting

MATERIAL	HARDENED STEELS HEAT RESISTANT STEELS		HARDENED STEELS		HARDENED STEELS		HARDENED STEELS		HARDENED STEELS		HARDENED STEELS	
	HARDNESS		HARDNESS		HARDNESS		HARDNESS		HARDNESS		HARDNESS	
	HRc 30~ HRc 40		HRc 40~ HRc 50		HRc 50~ HRc 55		HRc 55~ HRc 60		HRc 60~ HRc 65		HRc 65~ HRc 70	
DIAMETER(mm)	RPM	FEED	RPM	FEED	RPM	FEED	RPM	FEED	RPM	FEED	RPM	FEED
1	48000	1050	38000	820	25500	510	20500	310	16000	190	12500	125
2	33300	1200	26000	970	17500	600	14500	370	11000	230	9500	165
3	21800	1200	17300	970	11500	600	9500	370	7500	230	6400	165
4	16700	1250	13200	1000	8800	625	7200	385	5600	240	4750	170
5	15700	1450	12500	1150	8300	710	6400	410	5100	260	4450	190
6	13100	1350	10350	1100	6900	690	5300	400	4200	255	3700	185
8	9880	1320	7800	1030	5200	635	4000	365	3200	235	2800	170
10	7800	1200	6150	970	4100	590	3200	340	2550	220	2200	160
12	6650	1200	5250	970	3500	590	2650	340	2100	220	1860	160
16	4900	1050	3900	840	2600	520	2000	300	1600	190	1400	140
20	3900	950	3100	750	2050	475	1600	275	1300	175	1100	125

RPM = rev. / min.
FEED = mm / min.

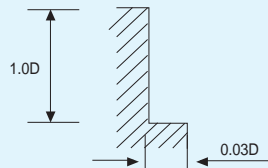

ZE704, ZE714, ZE724 series ▶ Side Cutting

MATERIAL	HARDENED STEELS HEAT RESISTANT STEELS		HARDENED STEELS		HARDENED STEELS		HARDENED STEELS		HARDENED STEELS		HARDENED STEELS	
	HARDNESS	HRc 30~ HRc 40	HRc 40~ HRc 50	HRc 50~ HRc 55	HRc 55~ HRc 60	HRc 60~ HRc 65	HRc 65~ HRc 70					
DIAMETER(mm)	RPM	FEED	RPM	FEED	RPM	FEED	RPM	FEED	RPM	FEED	RPM	FEED
1	48000	1480	38000	1050	25500	710	20500	430	16000	270	12500	175
2	33300	1750	26000	1250	17500	840	14500	520	11000	320	9500	230
3	21800	1750	17300	1250	11500	840	9500	520	7500	320	6400	230
4	16700	1800	13200	1300	8800	880	7200	540	5600	335	4750	240
5	15700	2000	12500	1500	8300	1000	6400	580	5100	370	4450	270
6	13100	1950	10350	1400	6900	950	5300	560	4200	350	3700	260
8	9880	1880	7800	1350	5200	900	4000	520	3200	330	2800	240
10	7800	1750	6150	1260	4100	840	3200	480	2550	310	2200	220
12	6650	1750	5250	1260	3500	840	2650	480	2100	300	1860	220
16	4900	1500	3900	1100	2600	730	2000	420	1600	270	1400	200
20	3900	1300	3100	970	2050	650	1600	380	1300	250	1100	180

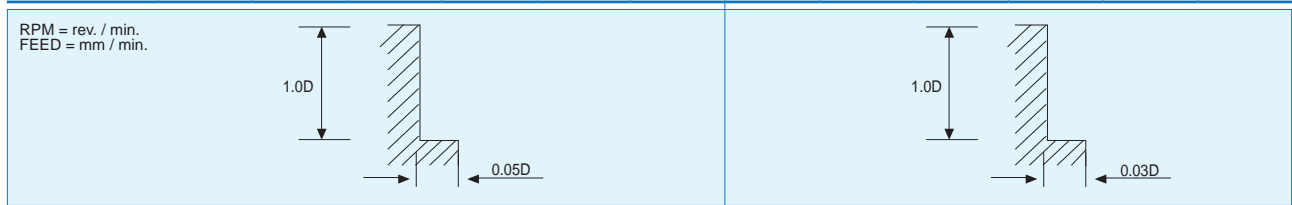

ZR702, ZR732 series ▶ Slotting

MATERIAL	HARDENED STEELS HEAT RESISTANT STEELS		HARDENED STEELS		HARDENED STEELS		HARDENED STEELS		HARDENED STEELS		HARDENED STEELS	
	HARDNESS	HRc 30~ HRc 40	HRc 40~ HRc 50	HRc 50~ HRc 55	HRc 55~ HRc 60	HRc 60~ HRc 65	HRc 65~ HRc 70					
DIAMETER(mm)	RPM	FEED	RPM	FEED	RPM	FEED	RPM	FEED	RPM	FEED	RPM	FEED
2	33300	680	26000	544	17500	336	14500	208	11000	128	9500	92
3	21800	680	17300	544	11500	336	9500	208	7500	128	6400	92
4	16700	704	13200	560	8800	352	7200	216	5600	136	4750	94
5	15700	800	12500	644	8300	400	6400	228	5100	144	4450	106
6	13100	760	10350	616	6900	384	5300	224	4200	144	3700	104
8	9880	744	7800	576	5200	356	4000	204	3200	132	2800	96
10	7800	680	6150	544	4100	332	3200	192	2550	124	2200	90
12	6650	680	5250	544	3500	332	2650	192	2100	124	1860	90
16	4900	584	3900	464	2600	292	2000	168	1600	108	1400	78
20	3900	528	3100	420	2050	268	1600	168	1300	100	1100	70

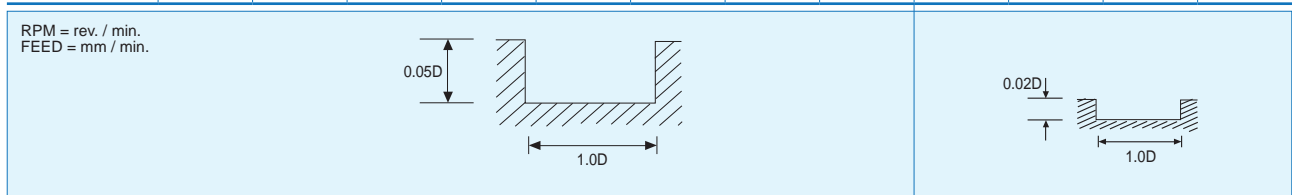

ZR702, ZR732 series ▶ Side Cutting

MATERIAL	HARDENED STEELS HEAT RESISTANT STEELS		HARDENED STEELS		HARDENED STEELS		HARDENED STEELS		HARDENED STEELS		HARDENED STEELS	
	HARDNESS		HARDNESS		HARDNESS		HARDNESS		HARDNESS		HARDNESS	
	HRc 30~ HRc 40		HRc 40~ HRc 50		HRc 50~ HRc 55		HRc 55~ HRc 60		HRc 60~ HRc 65		HRc 65~ HRc 70	
DIAMETER(mm)	RPM	FEED	RPM	FEED	RPM	FEED	RPM	FEED	RPM	FEED	RPM	FEED
2	33300	960	26000	776	17500	480	14500	296	11000	184	9500	132
3	21800	960	17300	776	11500	480	9500	296	7500	184	6400	132
4	16700	1000	13200	800	8800	500	7200	308	5600	192	4750	136
5	15700	1160	12500	920	8300	568	6400	328	5100	208	4450	152
6	13100	1080	10350	880	6900	552	5300	320	4200	204	3700	148
8	9880	1056	7800	824	5200	508	4000	292	3200	188	2800	136
10	7800	960	6150	776	4100	472	3200	272	2550	176	2200	128
12	6650	960	5250	776	3500	472	2650	272	2100	176	1860	128
16	4900	840	3900	672	2600	416	2000	240	1600	152	1400	112
20	3900	760	3100	600	2050	380	1600	220	1300	140	1100	100

RPM = rev. / min.
FEED = mm / min.

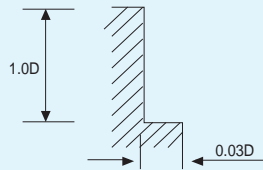

ZR704, ZR714, ZR724, ZR734 series

MATERIAL	HARDENED STEELS HEAT RESISTANT STEELS		HARDENED STEELS		HARDENED STEELS		HARDENED STEELS		HARDENED STEELS		HARDENED STEELS	
	HARDNESS		HARDNESS		HARDNESS		HARDNESS		HARDNESS		HARDNESS	
	HRc 30~ HRc 40		HRc 40~ HRc 50		HRc 50~ HRc 55		HRc 55~ HRc 60		HRc 60~ HRc 65		HRc 65~ HRc 70	
DIAMETER(mm)	RPM	FEED	RPM	FEED	RPM	FEED	RPM	FEED	RPM	FEED	RPM	FEED
3	21800	1400	17300	1000	11500	672	9500	416	7500	256	6400	184
4	16700	1440	13200	1040	8800	704	7200	432	5600	268	4750	192
5	15700	1600	12500	1200	8300	800	6400	464	5100	296	4450	216
6	13100	1560	10350	1120	6900	760	5300	448	4200	280	3700	208
8	9880	1504	7800	1080	5200	720	4000	416	3200	264	2800	192
10	7800	1400	6150	1008	4100	672	3200	384	2550	248	2200	176
12	6650	1400	5250	1008	3500	672	2650	384	2100	240	1860	176
16	4900	1200	3900	880	2600	584	2000	336	1600	216	1400	160
20	3900	1040	3100	776	2050	520	1600	304	1300	200	1100	144

RPM = rev. / min.
FEED = mm / min.

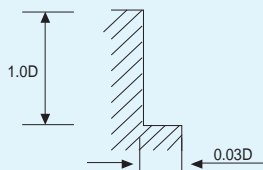

▣ ZR706, ZR736, ZE716, ZE726 series

MATERIAL	HARDENED STEELS HEAT RESISTANT STEELS		HARDENED STEELS		HARDENED STEELS		HARDENED STEELS		HARDENED STEELS		HARDENED STEELS	
HARDNESS	HRc 30~ HRc 40		HRc 40~ HRc 50		HRc 50~ HRc 55		HRc 55~ HRc 60		HRc 60~ HRc 65		HRc 65~ HRc 70	
DIAMETER(mm)	RPM	FEED	RPM	FEED	RPM	FEED	RPM	FEED	RPM	FEED	RPM	FEED
6	24800	5350	23500	4900	16000	4900	13500	3300	10500	2100	8000	1450
8	20000	5500	19000	5000	12000	4600	10000	3100	8000	2000	6000	1400
10	16000	4900	15500	4500	9500	4100	8000	2900	6400	1800	4800	1300
12	13000	4500	12500	4100	8000	3800	6600	2500	5300	1600	4000	1150
16	10000	4000	9700	3700	6000	3400	5000	2300	4000	1250	3000	870
20	8000	3350	7800	3400	4800	3200	4000	2100	3200	1020	2400	690

RPM = rev. / min.
FEED = mm / min.

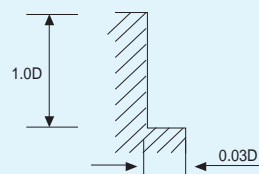
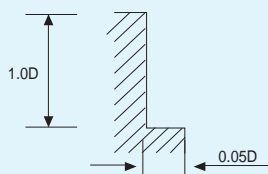

▣ ZSLNB series

MATERIAL	ALLOY STEELS HEAT RESISTANT STEELS			HARDENED STEELS			HARDENED STEELS			COPPER		
HARDNESS	HRc 30~ HRc 45			HRc 45~ HRc 55			HRc 55~ HRc 65					
DIAMETER(mm)	RPM	FEED	Ae(mm)	RPM	FEED	Ae(mm)	RPM	FEED	Ae(mm)	RPM	FEED	Ae(mm)
0.5	34100-49500	600-870	0.007-0.028	31900-35200	490-540	0.005-0.023	31900-35200	440-480	0.005-0.021	49000-50000	1100-1400	0.010-0.042
0.6	28600-40700	590-850	0.007-0.034	26400-29700	480-540	0.006-0.028	26400-29700	400-480	0.006-0.025	42000-50000	1100-1700	0.011-0.050
0.8	22000-30800	640-890	0.016-0.064	19800-22000	490-550	0.013-0.052	19800-22000	440-500	0.012-0.048	31000-50000	1100-2250	0.024-0.096
1.0	17600-24200	600-850	0.008-0.080	15400-17600	470-540	0.007-0.065	15400-17600	440-500	0.006-0.060	24000-49500	1100-2200	0.012-0.120
1.2	14300-18700	590-780	0.024-0.032	12000-14000	480-540	0.020-0.026	12000-14000	420-480	0.018-0.024	28500-38500	1480-1950	0.036-0.048
1.5	11000-14300	580-760	0.031-0.048	10000-11500	480-540	0.025-0.039	10000-11500	420-480	0.023-0.036	17000-28500	1100-1950	0.046-0.072
2.0	8500-11000	590-800	0.024-0.160	7900-8800	470-530	0.020-0.130	7900-8800	440-480	0.018-0.120	12600-24000	1100-2150	0.036-0.240
3.0	5700-8200	730-1000	0.064-0.24	5300-5800	590-650	0.052-0.195	5300-5800	550-620	0.048-0.120	11900-17000	1850-2700	0.096-0.360
4.0	4300-6200	680-990	0.080-0.320	3950-4400	550-620	0.065-0.260	3850-4400	530-570	0.060-0.240	6600-12500	1260-2500	0.120-0.480

RPM = rev. / min.
FEED = mm / min.

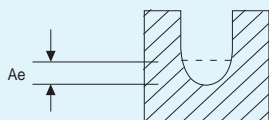

▣ ZSLNS20, ZSLNS40 series

MATERIAL	ALLOY STEELS HEAT RESISTANT STEELS			HARDENED STEELS			HARDENED STEELS			COPPER		
HARDNESS	HRc 30~ HRc 45			HRc 45~ HRc 55			HRc 55~ HRc 65					
DIAMETER(mm)	RPM	FEED	Ae(mm)	RPM	FEED	Ae(mm)	RPM	FEED	Ae(mm)	RPM	FEED	Ae(mm)
0.4	34100-50000	350-590	0.005-0.028	30500-35200	295-340	0.003-0.020	18300-24600	120-200	0.002-0.012	48000-50000	790-920	0.008-0.048
0.5	25650-33000	370-470	0.006-0.035	23750-26000	285-315	0.004-0.025	14200-18000	115-130	0.003-0.015	44000-50000	800-1150	0.010-0.060
0.6	20900-35200	330-560	0.007-0.030	19900-22000	260-290	0.005-0.021	11900-15500	100-120	0.003-0.013	37500-50000	770-1250	0.011-0.051
0.8	16150-26400	360-590	0.009-0.040	15200-16700	280-310	0.006-0.028	9000-11700	110-125	0.004-0.017	28500-47000	770-1300	0.015-0.068
1.0	12300-18700	350-540	0.011-0.028	10500-11500	250-280	0.008-0.020	6300-8050	100-115	0.005-0.012	22500-34000	810-1300	0.018-0.048
1.2	10450-17600	350-590	0.025-0.070	9100-10000	250-280	0.015-0.042	5400-7000	100-115	0.009-0.026	22500-31500	950-1350	0.036-0.101
1.5	9100-17600	430-830	0.017-0.077	7000-8000	250-280	0.012-0.055	4300-5500	100-115	0.007-0.033	14500-25000	770-1320	0.028-0.132
2.0	6350-10550	340-570	0.021-0.140	6100-6700	270-300	0.015-0.100	3600-4700	100-120	0.009-0.060	11500-18500	770-1250	0.036-0.240
3.0	4300-7050	550-900	0.056-0.210	3990-4600	445-515	0.040-0.150	2400-3200	105-310	0.024-0.090	9000-13000	1400-2110	0.096-0.360
4.0	3200-5300	400-675	0.074-0.280	3000-3400	335-380	0.053-0.200	1800-2400	75-230	0.032-0.120	6750-9750	1050-1575	0.128-0.480

RPM = rev. / min.
FEED = mm / min.

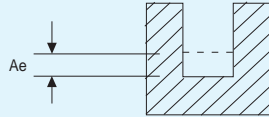

▣ DB412 series

MATERIAL	HARDENED STEELS		HARDENED STEELS		HARDENED STEELS		HARDENED STEELS	
HARDNESS	HRc45 ~ HRc50		HRc50 ~ HRc55		HRc55 ~ HRc60		HRc60 ~ HRc70	
STRENGTH	1500 ~ 1750N/mm ²		1750 ~ 2000N/mm ²		2000 ~ 2080N/mm ²		2080N/mm ²	
DIAMETER(mm)	RPM	FEED	RPM	FEED	RPM	FEED	RPM	FEED
1	20000	460	20000	400	20000	350	20000	240
1.5	16300	640	16100	580	16000	570	14200	360
2	14500	800	14200	740	13850	760	11300	465
2.5	13400	950	13000	890	12600	920	9600	560
3	12700	1100	12300	1050	11800	1000	8400	660
4	10600	1100	10300	1050	9800	1000	6650	650
5	9400	1100	9050	1050	8600	950	5600	680
6	8600	1150	8250	1100	7850	950	4850	700
8	7000	1050	6700	1000	6350	950	3800	650
10	6050	1000	5800	960	5450	900	3200	620
12	5450	1000	5200	960	4900	900	2750	610

RPM=rev. / min.
FEED=mm / min.

Ae: D1~D4=0.05XD
D5~D8=0.025mm
D10~D20=0.30mm
Ap: D1~D20=0.1 X D

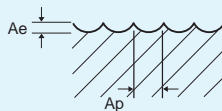

DB612 series ▶ Rib Processing

MATERIAL	NON-ALLOYED STEELS ALLOY STEELS · CAST IRON			ALLOY STEELS HEAT RESISTANT STEELS			HARDENED STEELS		
HARDNESS	~ HRC30			HRC30 ~ HRC45			HRC45 ~ HRC55		
STRENGTH	~ 1000N/mm ²			1000 ~ 1500N/mm ²			1500 ~ 2000N/mm ²		
DIAMETER(mm)	RPM	FEED	Ae(mm)	RPM	FEED	Ae(mm)	RPM	FEED	Ae(mm)
0.5	33000~42000	200~540	0.023~0.045	24000~30000	100~300	0.023~0.045	15000~19000	100~2000	0.005~0.009
0.6	33000~42000	250~700	0.027~0.054	24000~30000	120~385	0.027~0.054	15000~19000	120~250	0.005~0.011
0.8	33000~42000	250~700	0.036~0.072	24000~30000	120~385	0.036~0.072	15000~19000	120~250	0.007~0.014
1.0	30000~38000	275~770	0.045~0.090	22000~27000	140~430	0.045~0.090	13500~17500	140~280	0.009~0.018
1.2	25000~32000	275~860	0.055~0.100	18000~23000	140~430	0.055~0.100	11500~14500	140~280	0.010~0.022
1.4	22000~27000	275~860	0.062~0.125	16000~19000	140~430	0.062~0.125	10000~12500	140~280	0.012~0.025
1.5	20000~25000	275~860	0.070~0.135	14500~18500	140~430	0.070~0.135	9500~11500	140~280	0.014~0.028
1.6	19000~25000	275~860	0.075~0.145	14000~17500	140~430	0.075~0.145	9000~11000	140~280	0.015~0.030
1.8	18000~23000	275~860	0.080~0.160	12500~16000	140~430	0.080~0.160	8000~10000	140~280	0.016~0.032
2	16000~20000	275~860	0.090~0.180	11500~14500	140~430	0.090~0.180	7500~9000	140~280	0.018~0.035
3	11000~14000	275~860	0.135~0.270	7500~9500	140~430	0.135~0.270	5000~6000	140~280	0.028~0.055
4	9000~12000	275~860	0.180~0.360	6100~8200	140~430	0.180~0.360	4000~5000	140~280	0.035~0.070

RPM=rev. / min.
FEED=mm / min.

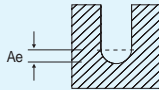

ZE612 series ▶ Rib Processing

MATERIAL	NON-ALLOYED STEELS ALLOY STEELS · CAST IRON			ALLOY STEELS HEAT RESISTANT STEELS			HARDENED STEELS		
HARDNESS	~ HRC30			HRC30 ~ HRC45			HRC45 ~ HRC55		
STRENGTH	~ 1000N/mm ²			1000 ~ 1500N/mm ²			1500 ~ 2000N/mm ²		
DIAMETER(mm)	RPM	FEED	Ae(mm)	RPM	FEED	Ae(mm)	RPM	FEED	Ae(mm)
0.4	33000~42000	220~490	0.007~0.018	24000~30000	100~375	0.007~0.018	15000~18000	35~100	0.004~0.008
0.5	33000~42000	220~190	0.009~0.022	24000~30000	100~375	0.009~0.022	15000~18000	35~100	0.004~0.009
0.6	33000~42000	275~630	0.011~0.026	24000~30000	120~485	0.011~0.026	15000~18000	45~120	0.005~0.011
0.7	33000~42000	275~630	0.012~0.031	24000~30000	120~485	0.012~0.031	15000~18000	45~120	0.006~0.013
0.8	28500~37000	310~700	0.014~0.035	20500~26000	130~530	0.014~0.035	13000~15500	50~140	0.007~0.015
0.9	26000~33000	310~800	0.030~0.060	19000~24000	180~600	0.030~0.060	11500~13500	60~145	0.008~0.016
1.0	24000~30000	310~900	0.045~0.090	16500~21000	210~660	0.045~0.090	10500~13500	75~145	0.009~0.018
1.2	19500~24000	310~990	0.055~0.100	14000~17000	210~660	0.055~0.100	9000~11000	75~145	0.010~0.022
1.4	17000~21000	310~990	0.062~0.125	12000~15000	210~660	0.062~0.125	7500~9500	75~145	0.012~0.025
1.5	15500~20000	310~990	0.070~0.135	11000~14500	210~660	0.070~0.135	7000~8500	75~145	0.014~0.028
1.6	15000~19000	310~990	0.075~0.145	11000~13500	210~660	0.075~0.145	6500~8500	75~145	0.015~0.030
1.8	14000~18000	310~990	0.080~0.160	10000~12000	210~660	0.080~0.160	6000~7500	75~145	0.016~0.032
2.0	12500~15500	310~990	0.090~0.180	9000~11000	210~660	0.090~0.180	5500~7000	75~145	0.018~0.035
2.5	10000~13000	310~990	0.112~0.235	7000~9000	210~660	0.112~0.235	4500~5500	75~145	0.022~0.045
3.0	8500~10500	310~990	0.135~0.270	6000~7500	210~660	0.135~0.270	3500~4500	75~145	0.028~0.055
4.0	6500~8000	310~990	0.180~0.360	4500~5500	210~660	0.180~0.360	2700~3500	75~145	0.036~0.072

RPM=rev. / min.
FEED=mm / min.

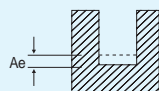

□ X-STAR series

WORKPIECE	LOW CARBON STEELS		LOW CARBON STEELS		MED ALLOY STEELS		MOLD&DIE STEELS		CAST IRON-GRAY		CAST IRON-GRAY	
HARDNESS	~HB175		~HB275		~HB275		~HB275		~HB200		~HB300	
DIAMETER(mm)	RPM	FEED	RPM	FEED	RPM	FEED	RPM	FEED	RPM	FEED	RPM	FEED
3	16500	335	13585	276	11320	230	5820	118	15360	300	7765	158
4	12340	326	10190	326	8520	340	4380	175	11550	462	5810	232
5	9895	502	8150	413	6790	345	3490	177	9215	468	4655	236
6	8250	586	6795	483	5660	403	2910	207	7680	546	3880	276
8	6185	754	5095	620	4245	517	2185	266	5760	702	2910	354
10	4950	955	4075	786	3395	656	1745	337	4610	889	2330	449
12	4125	963	3395	793	2830	661	1455	340	3840	897	1940	453
14	3535	890	2910	733	2425	592	1250	314	3290	829	1665	419
16	3095	817	2545	672	2125	561	1090	288	2880	761	1455	384
18	2750	809	2265	667	1885	556	970	285	2560	754	1295	381
20	2475	804	2040	662	1700	552	875	283	2305	749	1165	378
25	1975	631	1630	521	1360	435	700	230	1850	600	930	300

RPM = rev. / min.
FEED = mm / min.

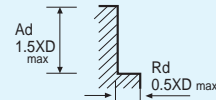
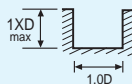

- Use a rigid and precise machines and holders.
- Use a suitable cutting oil.

□ X-STAR series

WORKPIECE	CAST IRON MALLEABLE		STAINLESS 300 SERIES		STAINLESS 400 SERIES		STAINLESS PH SERIES		TITANIUM ALLOYS		HIGH TEMP ALLOYS	
HARDNESS	~HB300		~HB275		~HB185		~HB325		~HB295		~HB300	
DIAMETER(mm)	RPM	FEED	RPM	FEED	RPM	FEED	RPM	FEED	RPM	FEED	RPM	FEED
3	4850	95	9705	175	13585	250	8085	125	9705	225	2590	50
4	3660	146	7245	290	10190	407	6050	242	7245	290	1910	76
5	2910	147	5820	300	8150	430	4850	250	5820	355	1550	75
6	2425	173	4850	355	6795	560	4045	300	4850	405	1295	75
8	1820	221	3640	405	5095	635	3030	355	3640	455	970	100
10	1455	280	2910	405	4075	635	2425	355	2910	455	775	100
12	1215	283	2425	405	3395	635	2020	355	2425	455	645	100
14	1040	262	2080	405	2910	635	1735	355	2080	455	555	100
16	910	240	1820	405	2545	635	1515	355	1820	455	485	100
18	810	238	1615	380	2265	560	1350	300	1615	405	430	100
20	730	236	1455	380	2040	560	1215	300	1455	405	390	100
25	585	187	1160	370	1630	560	970	300	1160	405	305	73

RPM = rev. / min.
FEED = mm / min.

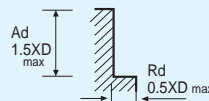
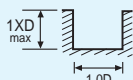

- Use a rigid and precise machines and holders.
- Use a suitable cutting oil.

□ X-STAR series ▶ Slotting

WORKPIECE	HARDENED STEELS	
HARDNESS	HRc30~45	
DIAMETER(mm)	RPM	FEED
3	6900	552
4	5175	414
5	4140	331
6	3450	414
8	2588	414
10	2070	414
12	1725	414
14	1479	414
16	1294	414
18	1150	368
20	1035	414
25	828	397

RPM = rev. / min.
FEED = mm / min.

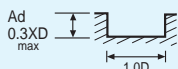

- Use a rigid and precise machines and holders.
- Use a suitable cutting oil.

▣ X-STAR series ▶ Side Cutting

WORKPIECE HARDNESS	HARDENED STEELS HRc30~45	
DIAMETER(mm)	RPM	FEED
3	8493	679
4	6369	510
5	5096	611
6	4246	849
8	3185	764
10	2548	713
12	2123	764
14	1820	728
16	1592	701
18	1415	679
20	1274	662
25	1019	611

RPM = rev. / min.
FEED = mm / min.

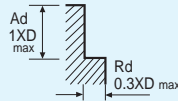

- Use a rigid and precise machines and holders.
- Use a suitable cutting oil.

▣ X-STAR series ▶ High Speed Cutting

WORKPIECE HARDNESS	HARDENED STEELS HRc30~45	
DIAMETER(mm)	RPM	FEED
3	18047	2166
4	13535	1624
5	10828	1732
6	9023	2166
8	6768	1895
10	5414	1732
12	4512	1985
14	3867	1856
16	3384	1895
18	3008	1805
20	2707	1841
25	2166	1646

RPM = rev. / min.
FEED = mm / min.

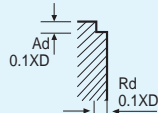

- Use a rigid and precise machines and holders.
- Use a suitable cutting oil.

DB312, DB402, DB502, DB512, DB522 series ▶ **General Cutting**

MATERIAL	NON-ALLOYED STEELS ALLOY STEELS · CAST IRON		ALLOY STEELS HEAT RESISTANT STEELS		HARDENED STEELS	
HARDNESS	~ HRC30		HRC30 ~ HRC40		HRC40 ~ HRC55	
STRENGTH	~ 1000N/mm ²		1000 ~ 1250N/mm ²		1500N/mm ²	
DIAMETER(mm)	RPM	FEED	RPM	FEED	RPM	FEED
1	16500	290	13300	230	6100	105
1.5	16500	405	12700	310	5590	140
2	15100	865	11200	565	4900	175
2.5	15100	865	11200	565	4900	175
3	13800	780	10500	530	4750	175
4	11000	850	8800	610	4410	205
5	9600	945	7600	665	3860	205
6	8900	1150	7200	955	3340	220
8	7500	1500	6050	1060	2590	255
10	6700	1750	5300	1170	2140	260
12	6150	2000	4900	1280	1840	280
16	5000	1950	3900	1220	1420	280
20	4350	1900	3400	1200	1170	290

RPM = rev. / min.
FEED = mm / min.

Ae : D1-D6=0.2mm
D8-D20=0.3mm
Ap : 0.2XD

Ae : D1-D6=0.2mm
D8-D20=0.3mm
Ap : 0.1XD

• Please reduce cutting speed around 20~30% from the above tablef or DB522 series.

DB312, DB402, DB502, DB512, DB522 series ▶ **High Speed Cutting**

MATERIAL	NON-ALLOYED STEELS · ALLOY STEELS · CAST IRON		ALLOY STEELS HEAT RESISTANT STEELS	
HARDNESS	~ HRC45		HRC30 ~ HRC40	
STRENGTH	~ 1500N/mm ²		1500 ~ 2000N/mm ²	
DIAMETER(mm)	RPM	FEED	RPM	FEED
1	26000	1500	26000	920
1.5	24000	1600	24000	990
2	22000	1700	22000	1080
2.5	22000	2000	20000	1130
3	22000	2300	17800	1200
4	22000	3350	14300	1300
5	22000	4150	12600	1380
6	22000	4600	11000	1440
8	17500	4600	8800	1440
10	14700	4450	7350	1380
12	12800	4450	6400	1330
16	10000	4000	5000	1150
20	8350	3650	4150	1060

RPM = rev. / min.
FEED = mm / min.

Ae : D1-D6=0.2mm
D8-D20=0.3mm
Ap : 0.2XD

Ae : D1-D6=0.2mm
D8-D20=0.3mm
Ap : 0.1XD

• Please reduce cutting speed around 20~30% from the above tablef or DB522 series.

DB514 series ▶ General Cutting

MATERIAL	NON-ALLOYED STEELS ALLOY STEELS · CAST IRON		ALLOY STEELS HEAT RESISTANT STEELS		HARDENED STEELS	
HARDNESS	~ HRC30		HRC30 ~ HRC40		HRC45 ~ HRC65	
STRENGTH	~ 1000N/mm ²		1000 ~ 1250N/mm ²		1500N/mm ²	
DIAMETER(mm)	RPM	FEED	RPM	FEED	RPM	FEED
3	13100	1020	10000	690	4520	220
4	10500	1110	8400	800	4200	270
5	9140	1230	7300	870	3680	270
6	7780	1260	6300	950	3160	280
8	5260	1430	4420	990	2100	280
10	4620	1530	3780	1070	1780	280
12	3780	1350	2940	990	1360	280
16	2740	1380	2320	980	1160	280
20	2100	1260	1900	950	840	280

<p>RPM = rev. / min. FEED = mm / min.</p> <p>Ae: D1~D6=0.2mm D8~D20=0.3mm Ap: 0.2 X D</p>		<p>Ae: D1~D6=0.2mm D8~D20=0.3mm Ap: 0.1 X D</p>
---	--	---

DB514 series ▶ High Speed Cutting

MATERIAL	NON-ALLOYED STEELS ALLOY STEELS · CAST IRON		HARDENED STEELS	
HARDNESS	~ HRC45		HRC45 ~ HRC65	
STRENGTH	~ 1500N/mm ²		~ 1500N/mm ²	
DIAMETER(mm)	RPM	FEED	RPM	FEED
3	21000	1500	17000	780
4	21000	2210	13660	870
5	21000	2700	12000	900
6	21000	3470	10500	940
8	15760	4260	7880	1110
10	13660	4580	6300	1260
12	10500	3950	5260	1260
16	8200	3950	3780	1060
20	6300	3780	2940	790

<p>RPM = rev. / min. FEED = mm / min.</p> <p>Ae: D1~D6=0.2mm D8~D20=0.3mm Ap: 0.05 X D</p>	
--	--

DB532 series ▶ General Cutting

MATERIAL	NON-ALLOYED STEELS ALLOY STEELS · CAST IRON		ALLOY STEELS HEAT RESISTANT STEELS		HARDENED STEELS	
HARDNESS	~ HRc30		HRc30 ~ HRc40		HRc45 ~ HRc65	
STRENGTH	~ 1000N/mm ²		1000 ~ 1250N//mm ²		1500N/mm ²	
DIAMETER(mm)	RPM	FEED	RPM	FEED	RPM	FEED
3	35000	2800	33000	2600	12000	900
4	26000	2300	25000	2200	9000	800
5	21000	2100	20000	2000	7000	700
6	17000	1900	16000	1800	6000	650
8	13000	1700	12000	1600	4500	550
10	10500	1450	10000	1400	3500	500
12	9000	1400	8000	1300	3000	450
16	6000	1200	5500	1100	2000	400

RPM = rev. / min.
FEED = mm / min.

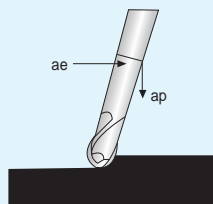

$$ae = 0.05 \times d1$$

$$ap = 0.02 \times d1$$

DB532 series ▶ High Speed Cutting

MATERIAL	NON-ALLOYED STEELS ALLOY STEELS · CAST IRON		ALLOY STEELS HEAT RESISTANT STEELS		HARDENED STEELS	
HARDNESS	~ HRc30		HRc30 ~ HRc40		HRc45 ~ HRc65	
STRENGTH	~ 1000N/mm ²		1000 ~ 1250N//mm ²		1500N/mm ²	
DIAMETER(mm)	RPM	FEED	RPM	FEED	RPM	FEED
3	47000	3700	44000	3500	17000	1400
4	35000	3200	33000	3000	13000	1200
5	28000	2800	27000	2600	10000	1100
6	23000	2600	22000	2400	8000	950
8	18000	2300	17000	2100	6000	850
10	14000	2000	13000	1900	5000	750
12	12000	1800	11000	1800	4000	700
16	9000	1600	8000	1500	3300	600

RPM = rev. / min.
FEED = mm / min.

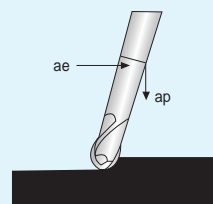

$$ae = 0.05 \times d1$$

$$ap = 0.02 \times d1$$

DB534 series ▶ General Cutting

MATERIAL	NON-ALLOYED STEELS ALLOY STEELS · CAST IRON		ALLOY STEELS HEAT RESISTANT STEELS		HARDENED STEELS	
HARDNESS	~ HRc30		HRc30 ~ HRc40		HRc45 ~ HRc65	
STRENGTH	~ 1000N/mm ²		1000 ~ 1250N//mm ²		1500N/mm ²	
DIAMETER(mm)	RPM	FEED	RPM	FEED	RPM	FEED
5	21000	4000	20000	4000	7000	1400
6	17000	4000	16000	3500	6000	1300
8	13000	3500	12000	3000	4500	1100
10	10500	3000	10000	2500	3500	1000
12	9000	2800	8000	2500	3000	950
16	6000	2800	5500	2200	2000	800

RPM = rev. / min.
FEED = mm / min.

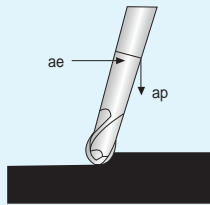

$$ae = 0.05 \times d1$$

$$ap = 0.02 \times d1$$

DB534 series ▶ High Speed Cutting

MATERIAL	NON-ALLOYED STEELS ALLOY STEELS · CAST IRON		ALLOY STEELS HEAT RESISTANT STEELS		HARDENED STEELS	
HARDNESS	~ HRc30		HRc30 ~ HRc40		HRc45 ~ HRc65	
STRENGTH	~ 1000N/mm ²		1000 ~ 1250N//mm ²		1500N/mm ²	
DIAMETER(mm)	RPM	FEED	RPM	FEED	RPM	FEED
5	28000	5600	27000	5300	11000	2100
6	23000	5100	22000	4900	9000	1900
8	18000	4600	17000	4300	7000	1700
10	14000	3900	13000	3700	5000	1400
12	12000	3700	11000	3500	4500	1300
16	9000	3100	8000	3000	3300	1100

RPM = rev. / min.
FEED = mm / min.

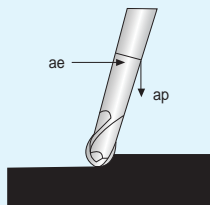

$$ae = 0.05 \times d1$$

$$ap = 0.02 \times d1$$

ZE302, ZE322, ZE402, ZE502, ZE522 series ▶ General Cutting

MATERIAL	ALLOY STEELS-HEAT RESISTANT STEELS		HARDENED STEELS		STAINLESS STEELS	
HARDNESS	HRc30 ~ HRc40		HRc40 ~ HRc50			
STRENGTH	1000 ~ 1250N/mm ²		1250 ~ 1750N/mm ²			
DIAMETER(mm)	RPM	FEED	RPM	FEED	RPM	FEED
2	9700	220	6350	135	5300	105
3	7500	240	4670	160	3880	135
4	6350	345	3880	205	3250	175
5	5300	370	3170	220	2650	185
6	4670	405	2830	255	2380	205
8	3530	435	2120	230	1760	205
10	2730	380	1680	185	1420	185
12	2310	320	1420	150	1140	150
16	1850	255	1140	125	890	125
20	1420	195	890	90	705	90
25	1150	150	705	80	580	70

RPM = rev. / min.
FEED = mm / min.

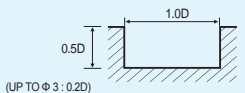

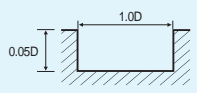

• Please reduce cutting speed around 20~30% from the above table for ZE522, ZE322 series.

ZE302, ZE322, ZE402, ZE502, ZE522 series ▶ High Speed Cutting

MATERIAL	ALLOY STEELS-HEAT RESISTANT STEELS		HARDENED STEELS		HARDENED STEELS		STAINLESS STEELS	
HARDNESS	HRc30 ~ HRc40		HRc40 ~ HRc50		HRc40 ~ HRc55			
STRENGTH	1000 ~ 1250N/mm ²		1250 ~ 1750N/mm ²		1750 ~ 2000N/mm ²			
DIAMETER(mm)	RPM	FEED	RPM	FEED	RPM	FEED	RPM	FEED
2	18000	665	11800	415	8700	175	9800	345
3	11000	655	6800	435	5600	185	6200	370
4	10300	725	6300	430	4300	185	5300	370
5	9350	715	5570	420	3700	185	4620	355
6	8200	750	4930	470	3250	185	4100	390
8	6300	770	3780	410	2470	185	3120	355
10	4830	750	2940	360	2000	160	2470	310
12	4100	750	2520	345	1680	160	2100	300
16	3260	715	2000	355	1890	150	1940	290
20	2520	665	1580	310	1680	150	1630	275
25	2000	635	1260	340	1570	150	1420	290

RPM = rev. / min.
FEED = mm / min.

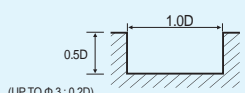

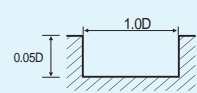

ZE503 series ▶ Side Cutting

MATERIAL	NON-ALLOY STEELS ALLOY STEELS-CAST IRON		ALLOY STEELS HEAT RESISTANT STEELS		STAINLESS STEELS		HARDENED STEELS		HARDENED STEELS	
HARDNESS	~ HRc30		HRc30 ~ HRc45				HRc45 ~ HRc55		HRc55 ~ HRc65	
STRENGTH	~ 1000N/mm ²		1000 ~ 1500N/mm ²				1500 ~ 2000N/mm ²		2000N/mm ² ~	
DIAMETER(mm)	RPM	FEED	RPM	FEED	RPM	FEED	RPM	FEED	RPM	FEED
6	5560	500	3360	310	2840	250	2000	60	1100	45
8	4200	530	2520	290	2100	265	1680	80	840	45
10	3260	460	2000	230	1680	230	1360	70	680	35
12	2740	390	1680	190	1360	180	1160	60	560	35
16	2200	310	1360	150	1060	150	900	45	440	20
18	1940	280	1210	135	950	130	790	35	380	20
20	1680	240	1060	120	840	115	680	30	320	20

RPM = rev. / min.
FEED = mm / min.

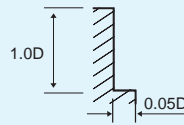

ZE503 series ▶ Slotting

MATERIAL	NON-ALLOY STEELS ALLOY STEELS-CAST IRON		ALLOY STEELS HEAT RESISTANT STEELS		STAINLESS STEELS		HARDENED STEELS		HARDENED STEELS	
HARDNESS	~ HRc30		HRc30 ~ HRc45				HRc45 ~ HRc55		HRc55 ~ HRc65	
STRENGTH	~ 1000N/mm ²		1000 ~ 1500N/mm ²				1500 ~ 2000N/mm ²		2000N/mm ² ~	
DIAMETER(mm)	RPM	FEED	RPM	FEED	RPM	FEED	RPM	FEED	RPM	FEED
6	5560	310	3360	200	2840	160	2000	50	1100	35
8	4200	340	2520	180	2100	160	1680	65	840	35
10	3260	300	2000	140	1680	145	1360	55	680	30
12	2740	250	1680	120	1360	120	1160	50	560	30
16	2200	200	1360	100	1060	100	900	35	440	20
18	1940	175	1210	85	950	85	790	30	380	20
20	1680	150	1060	70	840	70	680	25	320	20

RPM = rev. / min.
FEED = mm / min.

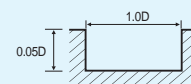
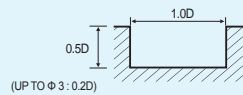

ZE304, ZE324, ZE404, ZE504, ZE524 series ▶ General Cutting

MATERIAL	NON-ALLOY STEELS ALLOY STEELS · CAST IRON		HARDENED STEELS				STAINLESS STEELS	
HARDNESS	~HRc30		HRc30 ~ HRc45		HRc45 ~ HRc55			
STRENGTH	~1000N/mm ²		1000 ~ 1500N/mm ²		1500 ~ 2000N/mm ²			
DIAMETER(mm)	RPM	FEED	RPM	FEED	RPM	FEED	RPM	FEED
2	12100	320	7900	195	2700	47	6600	160
3	9400	370	5840	230	2000	58	4850	195
4	7900	655	4850	405	1500	58	4070	320
5	6600	690	3970	415	1300	58	3320	345
6	5830	760	3530	470	1150	58	2980	380
8	4410	815	2650	435	880	58	2200	405
10	3420	700	2100	345	720	46	1760	345
12	2880	600	1760	290	590	46	1430	275
16	2310	470	1430	230	460	29	1150	230
20	1760	370	1110	185	340	29	880	175
25	1430	290	880	150	270	23	715	140

RPM = rev. / min.
FEED = mm / min.

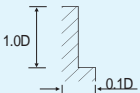

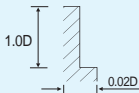

• Please reduce cutting speed around 20~30% from the above table for ZE524 & ZE324 series.

ZE304, ZE324, ZE404, ZE504, ZE524 series ▶ High Speed Cutting

MATERIAL	NON-ALLOY STEELS ALLOY STEELS · CAST IRON		HARDENED STEELS				STAINLESS STEELS	
HARDNESS	~HRc30		HRc30 ~ HRc45		HRc45 ~ HRc55			
STRENGTH	~1000N/mm ²		1000 ~ 1500N/mm ²		1500 ~ 2000N/mm ²			
DIAMETER(mm)	RPM	FEED	RPM	FEED	RPM	FEED	RPM	FEED
2	31400	1230	23500	520	12600	275	21600	465
3	19300	1210	13600	735	8900	390	13500	660
4	18100	1330	12600	865	7090	465	11800	775
5	16400	1310	11100	1010	6040	530	10300	910
6	14400	1380	9900	1100	5300	580	9100	990
8	11000	1430	7600	1090	3990	575	6900	980
10	8500	1380	5880	1110	3150	580	5420	1000
12	7200	1380	5040	1090	2620	575	4600	985
16	5700	1320	3990	1010	2000	535	3590	910
20	4400	1270	3150	930	1580	490	2840	840
25	3500	1170	2520	755	1260	390	2270	680

RPM = rev. / min.
FEED = mm / min.

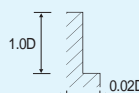

ZE506, ZE516 series ▶ General Speed Cutting

MATERIAL	NON-ALLOY STEELS ALLOY STEELS · CAST IRON		ALLOY STEELS HEAT RESISTANT STEELS		HARDENED STEELS		HARDENED STEELS	
HARDNESS	~ HRc30		HRc30 ~ HRc50		HRc50 ~ HRc60		HRc60 ~ HRc65	
STRENGTH	~ 1000N/mm ²		1000 ~ 1750N/mm ²		1750 ~ 2080N/mm ²		2080N/mm ²	
DIAMETER(mm)	RPM	FEED	RPM	FEED	RPM	FEED	RPM	FEED
6	5560	2000	3880	1370	1580	210	1100	130
8	4200	2000	2940	1370	1160	210	840	130
10	3360	2000	2320	1370	1000	210	680	130
12	2840	1680	2000	1160	840	180	560	110
16	2100	1260	1480	880	640	130	420	70
20	1680	1010	1160	690	500	110	320	60
25	1500	900	1100	600	430	90	260	50

RPM = rev. / min. FEED = mm / min.				
---------------------------------------	--	--	--	--

ZE506, ZE516 series ▶ High Speed Cutting

MATERIAL	HEAT RESISTANT STEELS HARDENED STEELS		HARDENED STEELS		HARDENED STEELS	
HARDNESS	~ HRc50		HRc50 ~ HRc60		HRc60 ~ HRc65	
STRENGTH	1750N/mm ²		1750~2080N/mm ²		2080N/mm ² ~	
DIAMETER(mm)	RPM	FEED	RPM	FEED	RPM	FEED
6	16800	6090	8400	3050	4200	1470
8	12600	6090	6300	3050	3160	1470
10	9980	5990	5040	3050	2520	1470
12	8400	5040	4200	2520	2100	1260
16	6300	3780	3160	1890	1580	950
20	5040	3050	2520	1470	1260	760
25	4500	2750	2200	1300	1120	670

RPM = rev. / min. FEED = mm / min.			
---------------------------------------	--	--	--

• Please reduce cutting speed around 20~30% from the above tablef or Extra long series.

□ ZM502, ZM522 series

MATERIAL	NON-ALLOYED STEELS ALLOY STEELS · CAST IRON		ALLOY STEELS HEAT RESISTANT STEELS		HARDENED STEELS	
HARDNESS	~ HRc30		HRc30 ~ HRc45		HRc45 ~ HRc55	
STRENGTH	~ 1000N/mm ²		1000~ 1500N/mm ²		1500 ~ 2000N/mm ²	
DIAMETER(mm)	RPM	FEED	RPM	FEED	RPM	FEED
2	6300	60	5040	50	3150	25
3	4410	70	3570	60	2200	30
4	3570	85	2840	70	1790	35
5	3050	105	2420	85	1580	40
6	2630	125	2100	105	1370	50
8	2000	135	1580	105	1050	50
10	1680	135	1370	105	840	50
12	1370	105	1160	95	700	40
16	1160	95	890	75	560	35
20	840	70	680	50	420	25

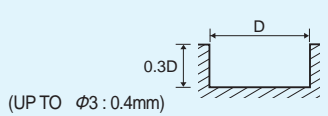
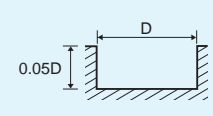
<p>RPM=rev. / min. FEED=mm / min.</p>  <p>(UP TO φ3 : 0.4mm)</p>	
---	---

□ ZM504, ZM524 series

MATERIAL	NON-ALLOY STEELS ALLOY STEELS · CAST IRON		ALLOY STEELS HEAT RESISTANT STEELS		HARDENED STEELS		HARDENED STEELS	
HARDNESS	~ HRc30		HRc30 ~ HRc45		HRc45 ~ HRc55		HRc55 ~ HRc65	
STRENGTH	~ 1000N/mm ²		1000 ~ 1500N/mm ²		1500 ~ 2000N/mm ²		2000N/mm ²	
DIAMETER(mm)	RPM	FEED	RPM	FEED	RPM	FEED	RPM	FEED
2	6300	100	5040	80	3150	45		
3	4410	115	3570	100	2200	55	1890	30
4	3570	140	2840	115	1790	60	1470	35
5	3050	180	2420	140	1580	70	1260	40
6	2630	215	2100	180	1370	90	1160	50
8	2000	230	1580	180	1050	90	840	50
10	1680	230	1370	180	840	90	670	50
12	1370	180	1160	160	700	70	560	40
16	1160	160	890	125	560	60	440	35
20	840	115	680	90	420	45	340	25

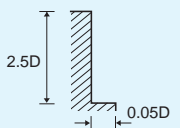
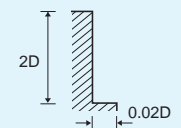
<p>RPM=rev. / min. FEED=mm / min.</p> 	
---	---

▣ ZR322, ZR502, ZR512, ZR522 series ▶ Side Cutting

MATERIAL	NON-ALLOYED STEELS ALLOY STEELS · CAST IRON		ALLOY STEELS HEAT RESISTANT STEELS		HARDENED STEELS	
HARDNESS	~ HRc30		HRc30 ~ HRc45		HRc45 ~ HRc55	
STRENGTH	~ 1000N/mm ²		1000~ 1500N///mm ²		1500 ~ 2000N//mm ²	
DIAMETER(mm)	RPM	FEED	RPM	FEED	RPM	FEED
3	6950	195	4500	150	3300	100
4	5600	240	3600	170	2700	105
5	4800	250	3050	210	2350	125
6	4150	250	2650	210	2050	125
8	3150	265	2000	210	1600	125
10	2150	265	1700	210	1250	125
12	1800	210	1500	185	1050	105
16	1800	185	1100	140	840	90
20	1300	130	860	105	625	65

RPM=rev. / min.
FEED=mm / min.

▣ ZR322, ZR502, ZR512, ZR522 series ▶ Slotting

MATERIAL	NON-ALLOYED STEELS ALLOY STEELS · CAST IRON		ALLOY STEELS HEAT RESISTANT STEELS		HARDENED STEELS	
HARDNESS	~ HRc30		HRc30 ~ HRc45		HRc45 ~ HRc55	
STRENGTH	~ 1000N/mm ²		1000~ 1500N///mm ²		1500 ~ 2000N//mm ²	
DIAMETER(mm)	RPM	FEED	RPM	FEED	RPM	FEED
3	6950	160	4500	80	3300	55
4	5600	195	3600	100	2700	60
5	4800	240	3050	115	2350	75
6	4150	290	2650	145	2050	90
8	3150	210	2000	145	1600	90
10	2150	250	1700	140	1250	90
12	1800	200	1500	135	1050	75
16	1800	215	1100	100	840	60
20	1300	160	860	70	625	45

RPM=rev. / min.
FEED=mm / min.

□ ZR324, ZR504, ZR514, ZR524 series

MATERIAL	NON-ALLOYED STEELS ALLOY STEELS · CAST IRON		ALLOY STEELS HEAT RESISTANT STEELS		HARDENED STEELS	
HARDNESS	~ HRc30		HRc30 ~ HRc45		HRc45 ~ HRc55	
STRENGTH	~ 1000N/mm ²		1000~ 1500N///mm ²		1500 ~ 2000N//mm ²	
DIAMETER(mm)	RPM	FEED	RPM	FEED	RPM	FEED
3	6950	195	4500	150	3300	100
4	5600	240	3600	170	2700	105
5	4800	250	3050	210	2350	125
6	4150	250	2650	210	2050	125
8	3150	265	2000	210	1600	125
10	2150	265	1700	210	1250	125
12	1800	210	1500	185	1050	105
16	1880	185	1100	140	840	90
20	1300	130	860	105	625	65

RPM=rev. / min.
FEED=mm / min.

□ ZR304H, ZR324H series

MATERIAL	NON-ALLOYED STEELS ALLOY STEELS · CAST IRON		ALLOY STEELS HEAT RESISTANT STEELS		HARDENED STEELS	
HARDNESS	~ HRc30		HRc30 ~ HRc45		HRc45 ~ HRc55	
STRENGTH	~ 1000N/mm ²		1000~ 1500N///mm ²		1500 ~ 2000N//mm ²	
DIAMETER(mm)	RPM	FEED	RPM	FEED	RPM	FEED
6	7000	910	4200	560	3000	140
8	5300	980	3200	530	2500	190
10	4100	840	2500	410	2050	165
12	3500	730	2100	340	1700	140

RPM=rev. / min.
FEED=mm / min.

□ ZF60, ZF61 series

MATERIAL	NON-ALLOY STEELS ALLOY STEELS-CAST IRON		ALLOY STEELS HEAT RESISTANT STEELS		STAINLESS STEELS		HARDENED STEELS		HARDENED STEELS	
HARDNESS	~ HRc30		HRc30 ~ HRc38		HRc38 ~ HRc45		HRc45 ~ HRc55		HRc55 ~ HRc65	
STRENGTH	~ 1000N/mm ²		1000 ~ 1200N/mm ²		1200 ~ 1400N/mm ²		1400 ~ 2000N/mm ²		2000N/mm ² ~	
DIAMETER(mm)	RPM	FEED	RPM	FEED	RPM	FEED	RPM	FEED	RPM	FEED
6	15600	2320	12400	840	8400	570	3400	260	2400	190
8	11600	2320	9200	840	6300	570	2400	240	1800	180
10	9200	2320	7600	840	5100	570	2000	290	1300	190
12	8000	2400	6000	800	4200	570	1680	260	1200	190
14	6800	2400	5200	840	3600	570	1400	200	900	130
16	6000	2400	4800	760	3300	510	1200	160	800	110
18	5200	2320	4400	720	2700	420	1100	150	700	100
20	4800	2160	3600	560	2400	360	1000	150	660	100
25	4300	2150	3200	620	2160	410	900	160	600	100

RPM=rev. / min.
FEED=mm / min.

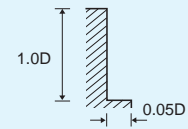
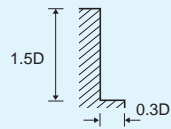

PK503 series

MATERIAL	Alloy Steels-High Carbon Steels				Prehardened Steels-Tool steels HRC30 ~ 40			
(V)m/min	130 ~ 150				100 ~ 120			
Diameter (mm)	(r.p.m.)	fz			(r.p.m.)	fz		
		Slot	Side Cutting	Slot		Slot	Side Cutting	Slot
6	7,400	0.030	0.045	0.018	5,800	0.025	0.030	0.012
8	5,600	0.035	0.062	0.025	4,400	0.030	0.045	0.018
10	4,600	0.045	0.075	0.030	3,500	0.040	0.048	0.019
12	3,700	0.050	0.087	0.035	3,000	0.045	0.052	0.020
14	3,200	0.055	0.090	0.036	2,500	0.053	0.056	0.022
16	2,800	0.055	0.090	0.036	2,200	0.060	0.060	0.024
20	2,200	0.080	0.095	0.038	1,800	0.066	0.066	0.026
	ap	1.0D	1.0D	0.5D		1.0D	1.0D	0.5D
	ae	1.0D	0.5D	1.0D		1.0D	0.3D	1.0D

MATERIAL	SUS304-316-Prehardened Steels HRC40 ~ 45				Titanium Alloy			
(V)m/min	50 ~ 70				30 ~ 50			
Diameter (mm)	(r.p.m.)	fz			(r.p.m.)	fz		
		Slot	Side Cutting	Slot		Slot	Side Cutting	Slot
6	3,200	0.020	0.030	0.012	2,100	0.017	0.020	0.008
8	2,400	0.030	0.040	0.016	1,600	0.025	0.025	0.010
10	1,900	0.040	0.055	0.022	1,300	0.035	0.040	0.016
12	1,600	0.045	0.065	0.026	1,100	0.040	0.050	0.020
14	1,360	0.048	0.070	0.028	900	0.043	0.053	0.021
16	1,200	0.050	0.075	0.030	800	0.045	0.055	0.022
20	1,000	0.052	0.083	0.033	600	0.050	0.057	0.023
	ap	0.5D	1.0D	0.5D		0.5D	1.0D	0.5D
	ae	1.0D	0.5D	1.0D		1.0D	0.3D	1.0D

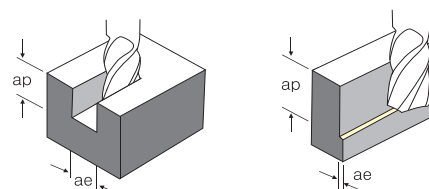

TX202, 222, 302 ...series

MATERIAL	NON - ALLOYED STEELS ALLOY STEELS TOOLS STEELS		ALLOY STEELS HEAT RESISANT STEELS		STAINLESS STEELS		CAST IRON		ALUMINUM ALLOYS		COPPER, BRASS NON-FERROUS METALS	
HARDNESS	~ HRc 30		HRc 30 ~ HRc 45									
STRENGTH	~ 1000N/mm ²		1000 ~ 1500N/mm ²									
DIAMETER(mm)	RPM	FEED	RPM	FEED	RPM	FEED	RPM	FEED	RPM	FEED	RPM	FEED
1	14300	105	8500	65	7150	50	18700	205	44000	330	24700	200
1.5	9350	150	5550	85	5600	80	12100	205	27500	385	20300	300
2	7850	160	5150	100	4300	80	9350	220	22000	460	16500	340
3	6100	180	3800	120	3150	100	6050	220	15400	460	11000	340
4	5150	255	3150	155	2650	130	4600	220	11000	460	8800	340
5	4300	270	2550	160	2150	135	3650	220	9150	460	6800	340
6	3800	300	2300	190	1950	155	2950	255	7600	485	5700	375
8	2850	325	1700	170	1450	155	2200	275	5700	485	4400	375
10	2200	280	1350	135	1150	135	1850	285	4600	485	3400	375
12	1850	240	1150	110	950	110	1450	295	3750	485	2850	375
14	1700	215	1050	100	850	100	1300	310	3300	485	2400	375
16	1500	185	950	95	700	95	1100	320	2850	485	2200	375
20	1150	145	700	70	550	70	900	340	2200	485	1700	375

RPM = rev. / min.
FEED = mm / min.

※ The FEED for long & extra long types, should be reduced by around 50%

□ TX204, 224, 304 ...series

MATERIAL	NON - ALLOYED STEELS ALLOY STEELS TOOLS STEELS		ALLOY STEELS HEAT RESISANT STEELS		STAINLESS STEELS		CAST IRON		ALUMINUM ALLOYS		COPPER, BRASS NON-FERROUS METALS	
HARDNESS	~ HRc 30		HRc 30 ~ HRc 45									
STRENGTH	~ 1000N/mm ²		1000 ~ 1500N/mm ²									
DIAMETER(mm)	RPM	FEED	RPM	FEED	RPM	FEED	RPM	FEED	RPM	FEED	RPM	FEED
1	17600	150	10250	85	8650	75	18700	620	44000	1050	24700	605
1.5	11800	215	7050	115	7050	120	12100	620	27500	1160	20300	910
2	9850	240	6450	145	5350	120	9350	640	22000	1320	16500	1035
3	7600	270	4750	170	3950	145	6050	640	15400	1320	11000	1035
4	6450	485	3950	300	3300	240	4600	640	11000	1320	8800	1035
5	5350	510	3200	305	2700	255	3650	640	9150	1320	6800	1035
6	4750	560	2850	350	2400	280	2950	770	7600	1430	5700	1100
8	3550	605	2150	325	1800	300	2200	815	5700	1430	4400	1100
10	2750	520	1700	255	1450	255	1850	860	4600	1430	3400	1100
12	2350	440	1450	215	1150	205	1450	900	3750	1430	2850	1100
14	2100	395	1300	195	1050	190	1300	945	3300	1430	2400	1100
16	1850	350	1150	170	950	170	1100	970	2850	1430	2200	1100
20	1450	270	900	135	700	130	900	1035	2200	1430	1700	1100

RPM = rev. / min.
FEED = mm / min.

※ The FEED for long & extra long types, should be reduced by around 50%

TXB202, 222, 232, 302 ...series

MATERIAL	CARBON STEELS ALLOY STEELS TOOLS STEELS		CARBON STEELS ALLOY STEELS TOOLS STEELS		HARDENED STEELS		CAST IRON		ALUMINUM ALLOYS	
HARDNESS	~ HRc 30		HRc 30 ~ HRc 45		HRc 45 ~ HRc 50					
STRENGTH	~ 1000N/mm ²		1000 ~ 1500N/mm ²		1500N/mm ²					
DIAMETER(mm)	RPM	FEED	RPM	FEED	RPM	FEED	RPM	FEED	RPM	FEED
2	12350	640	9150	415	4000	125	10500	220	30800	395
3	11400	575	8550	390	3800	125	7050	230	20500	395
4	8950	630	7150	450	3600	150	5150	285	15400	395
5	7800	700	6200	490	3100	150	4150	330	12100	470
6	7250	870	5900	705	2700	160	3400	360	10300	470
8	6100	1090	4900	785	2050	190	2500	460	7900	540
10	5450	1330	4350	870	1750	190	2050	460	6150	540
12	4990	1500	3950	950	1500	210	1750	460	5150	630
14	4530	1495	3600	925	1300	210	1400	460	4300	630
16	4085	1470	3200	905	1150	210	1300	460	3850	540
18	3800	1425	3000	890	1050	210	1100	460	3400	540
20	3550	1425	2800	885	950	210	1050	420	2950	540

RPM = rev. / min.
FEED = mm / min.

Ae : D1~D6=0.2mm
D8~D20=0.3mm
Ap : 0.2D

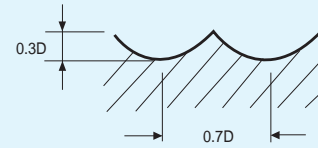
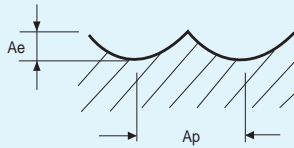

※ The FEED for long & extra long types, should be reduced by around 50%

SM503 series ▶ Slotting

MATERIAL	CARBON STEELS · ALLOY STEELS · TOOLS STEELS						CAST IRON		STAINLESS STEEL		COPPER ALLOYS		TITANIUM ALLOYS		INCONEL	
HARDNESS	~HRc2040		HRc20 ~ HRc30		HRc30 ~ HRc45											
STRENGTH	1000N/mm ²		800 ~ 1000N/mm ²		1500 ~ 1500N/mm ²											
DIAMETER(mm)	RPM	FEED	RPM	FEED	RPM	FEED	RPM	FEED	RPM	FEED	RPM	FEED	RPM	FEED	RPM	FEED
3	10080	950	7750	740	5550	395	6700	520	5550	320	8300	360	5550	395	2200	100
4	7550	1400	5850	1100	4200	595	5050	550	4200	320	6200	400	4200	595	1650	105
6	5050	1650	3850	1250	2800	700	3350	660	2800	370	4100	440	2800	700	1150	130
8	3750	1700	2950	1330	2100	710	2500	665	2100	375	3100	500	2100	710	850	120
10	3050	1650	2300	1250	1650	655	2000	630	1650	355	2500	530	1650	665	650	120
12	2500	1500	2000	1200	1350	605	1650	570	1350	320	2000	550	1350	605	555	110

RPM=rev. / min.
FEED=mm / min.

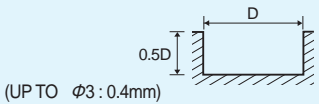

(UP TO Ø3 : 0.4mm)

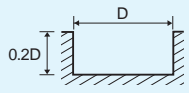

SM503 series ▶ Side Cutting

MATERIAL	CARBON STEELS · ALLOY STEELS · TOOLS STEELS						CAST IRON		STAINLESS STEEL		COPPER ALLOYS		TITANIUM ALLOYS		INCONEL	
HARDNESS	~HRc20		HRc20 ~ HRc30		HRc30 ~ HRc45											
STRENGTH	1000N/mm ²		800 ~ 1000N/mm ²		1500 ~ 1500N/mm ²											
DIAMETER(mm)	RPM	FEED	RPM	FEED	RPM	FEED	RPM	FEED	RPM	FEED	RPM	FEED	RPM	FEED	RPM	FEED
3	10080	1080	7750	850	5550	450	6700	605	5550	365	8300	390	5550	450	2200	110
4	7550	1630	5850	1260	4200	680	5050	630	4200	365	6200	440	4200	680	1650	125
6	5050	1910	3850	1470	2800	810	3350	755	2800	430	4100	490	2800	810	1150	150
8	3750	1950	2950	1500	2100	810	2500	770	2100	430	3100	550	2100	810	850	140
10	3050	1890	2300	1400	1650	775	2000	720	1650	415	2500	570	1650	775	650	140
12	2500	1700	2000	1340	1350	700	1650	665	1350	365	2000	620	1350	700	555	125

RPM=rev. / min.
FEED=mm / min.

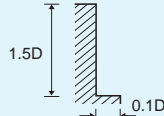

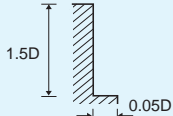

SM504 series

MATERIAL	ALLOY STEELS · CAST IRON		STAINLESS STEELS 300 SERIES TITANIUM		STAINLESS STEELS 400 SERIES	
HARDNESS	~HB 230					
DIAMETER(mm)	RPM	FEED	RPM	FEED	RPM	FEED
3	13500	275	6690	105	9350	145
4	10100	370	5050	135	7000	185
5	8090	410	4050	165	5600	230
6	6750	480	3350	190	4700	265
8	5050	620	2500	250	3500	340
10	4050	780	2050	320	2800	430
12	3370	750	1680	310	2350	435
14	2890	670	1400	280	2000	405
16	2500	630	1250	265	1750	370
18	2250	630	1100	260	1550	365
20	2000	620	1000	260	1400	365

RPM=rev. / min.
FEED=mm / min.

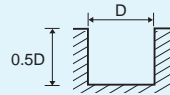

BC502 series

MATERIAL		UNALLOYED COPPER			
R	DIAMETER(mm)	RPM	FEED	Rd	Ad
0.5	1	41000	1660	0.040	0.063
0.75	1.5	27000	1830	0.068	0.087
1	2	20000	1780	0.089	0.112
1.25	2.5	16000	1840	0.115	0.090
1.5	3	13000	2220	0.171	0.168
2	4	10000	2080	0.208	0.200
2.5	5	8300	1990	0.240	0.200
3	6	6900	1940	0.281	0.250
4	8	5720	1000	0.175	0.400
5	10	4550	700	0.154	0.500
6	12	3770	600	0.159	0.600

RPM=rev. / min.
FEED=mm / min.

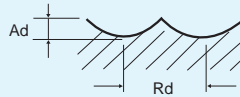

ZF62 series ▶ Slotting

MATERIAL	NON - ALLOYED STEELS ALLOY STEELS · CAST IRON		ALLOY STEELS HEAT RESISTANT STEELS		STAINLESS STEELS		INCONEL	
HARDNESS	~ HRc30		HRc30 ~ HRc45					
STRENGTH	~ 1000N/mm ²		1000 ~ 1500N/mm ²					
DIAMETER(mm)	RPM	FEED	RPM	FEED	RPM	FEED	RPM	FEED
6	16380	2680	13020	970	8820	670	3000	285
8	12180	2680	9660	970	6615	670	2250	270
10	9660	2680	7980	970	5355	660	1625	285
12	8400	2770	6300	925	4410	660	1500	285
16	6300	2770	5040	880	3465	590	1000	165
20	5040	2495	3780	650	2520	415	825	150

RPM=rev. / min.
FEED=mm / min.

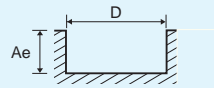
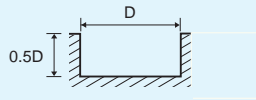

Ae : $\phi 4 \sim \phi 10 = 0.25 \times D$
 $\phi 12 \sim \phi 16 = 0.15 \times D$
 $\phi 18 \sim \phi 20 = 0.10 \times D$

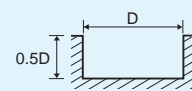

ZF62 series ▶ Side Cutting

MATERIAL	NON - ALLOYED STEELS ALLOY STEELS · CAST IRON		ALLOY STEELS HEAT RESISTANT STEELS		STAINLESS STEELS		INCONEL	
HARDNESS	~ HRc30		HRc30 ~ HRc45					
STRENGTH	~ 1000N/mm ²		1000 ~ 1500N/mm ²					
DIAMETER(mm)	RPM	FEED	RPM	FEED	RPM	FEED	RPM	FEED
6	16380	2680	13020	970	8820	670	3000	285
8	12180	2680	9660	970	6615	670	2250	270
10	9660	2680	7980	970	5355	660	1625	285
12	8400	2770	6300	925	4410	660	1500	285
16	6300	2770	5040	880	3465	590	1000	165
20	5040	2495	3780	650	2520	415	825	150

RPM=rev. / min.
FEED=mm / min.

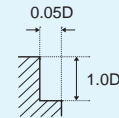
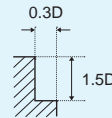
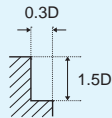

RC502 series

MATERIAL	UNALLOYED COPPER			
DIAMETER(mm)	RPM	FEED	RPM	FEED
3	44500	2350	50000	3700
4	33400	2100	50000	4700
6	22300	2100	33400	4900
8	16700	2100	25000	4700
10	13370	2100	20000	4800
12	11100	2100	16700	4700

RPM=rev. / min.
FEED=mm / min.

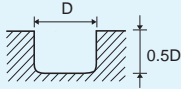
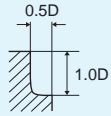
AE302 series

MATERIAL	ALLOY STEELS · CAST IRON		ALUMINIUM	
HARDNESS	~HB 230			
DIAMETER(mm)	RPM	FEED	RPM	FEED
1.0	16870	505	16870	845
1.5	13150	525	13150	790
2.0	11300	565	11300	790
2.5	10565	635	10565	845
3.0	10000	700	10000	900
4.0	10000	900	10000	1100
5.0	10000	1000	10000	1300
6.0	10000	1200	10000	1500
7.0	8850	1240	8850	1505
8.0	8000	1400	8000	1800
9.0	8000	1550	8000	1680
10.0	8000	1700	8000	2100
12.0	8000	2100	8000	2600
14.0	6000	1800	6000	2200
16.0	6000	1900	6000	2400
18.0	4000	1400	4000	1800
20.0	4000	1600	4000	1900

RPM=rev. / min.
FEED=mm / min.

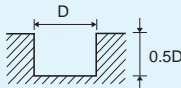

A : $\phi 3 - \phi 10 = 0.25 \times D$
 $\phi 12 - \phi 20 = 0.5 \times D$

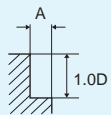

AE303, AE323 series ▶ Side Cutting

MATERIAL	ALUMINIUM · NONFERROUS METALS	
DIAMETER(mm)	RPM	FEED
3	7000	455
4	7000	546
5	7000	651
6	7000	756
8	5600	861
10	5600	1050
12	5600	882
14	4200	1106
16	4200	1211
18	2800	910
20	2800	956

RPM=rev. / min.
FEED=mm / min.

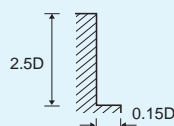

• Please reduce cutting speed around 20~30% from the above tablef or AE323 series.

AE303, AE323 series ▶ Slotting

MATERIAL	ALUMINIUM · NONFERROUS METALS	
DIAMETER(mm)	RPM	FEED
3	7000	350
4	7000	441
5	7000	504
6	7000	606
8	5600	700
10	5600	854
12	5600	1050
14	4200	903
16	4200	945
18	2800	700
20	2800	805

RPM=rev. / min.
FEED=mm / min.

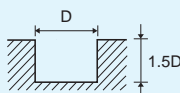

AF303 series ▶ Slotting

MATERIAL	ALUMINIUM · NONFERROUS METALS			
DIAMETER(mm)	RPM	FEED	RPM	FEED
6	10500	800	13500	1050
8	8000	700	10500	900
10	6500	750	8500	950
12	5250	800	6800	1050
16	4000	800	5200	1050
20	3200	800	4200	1050

RPM=rev. / min.
FEED=mm / min.

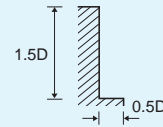
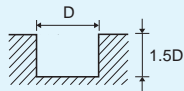

G series

MATERIAL	GRAPHITE	
DIAMETER(mm)	RPM	FEED
R0.5	16000	480
R0.75	16000	640
R1	16000	800
R1.5	16000	1450
R2	16000	2100
R3	15000	2950
R4	13000	3000
R5	11500	3050
R6	10500	3150
R8	8555	2960

RPM=rev. / min.
FEED=mm / min.

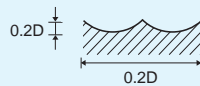

□ EB302, EB322, BB302 series

Work Material	SM50C,SCM,GC (~HRc30)		STD61,STD11 (HRc30~HRc45)		STD61 (HRc45~HRc55)		
	DIAMETER (mm)	RPM (mm ⁻¹)	FEED (mm/rev)	RPM (mm ⁻¹)	FEED (mm/rev)	RPM (mm ⁻¹)	FEED (mm/rev)
	20	1600	152	950	88	560	44
	25	1300	136	750	72	450	36
	30	1100	120	650	64	370	32
	40	800	96	500	56	280	24
	50	650	88	400	48	220	20

□ EB304, EB324 series

Work Material	SM50C,SCM,GC (~HRc30)		STD61,STD11 (HRc30~HRc45)		STD61 (HRc45~HRc55)		
	DIAMETER (mm)	RPM (mm ⁻¹)	FEED (mm/rev)	RPM (mm ⁻¹)	FEED (mm/rev)	RPM (mm ⁻¹)	FEED (mm/rev)
	20	1600	230	950	133	560	66
	25	1300	205	750	109	450	54
	30	1100	180	650	96	370	48
	40	800	145	500	85	280	36
	50	650	135	400	72	220	30

Hardness Conversion Table

Rm[N/mm ²]	HV 10	HB	HRc	Rm[N/mm ²]	HV 10	HB	HRc
240	75	71		920	287	273	28
255	80	76		940	293	278	29
270	85	81		970	302	287	30
285	90	86		995	310	295	31
305	95	90		1020	317	301	32
320	100	95		1050	327	311	33
335	105	100		1080	336	319	34
350	110	105		1110	345	328	35
370	115	109		1140	355	337	36
385	120	114		1170	364	346	37
400	125	119		1200	373	354	38
415	130	124		1230	382	363	39
430	135	128		1260	392	372	40
450	140	133		1300	403	383	41
465	145	138		1330	413	393	42
480	150	143		1360	423	402	43
495	155	147		1400	434	413	44
510	160	152		1440	446	424	45
530	165	157		1480	458	435	46
545	170	162		1530	473	449	47
560	175	166		1570	484	460	48
575	180	171		1620	497	472	49
595	185	176		1680	514	488	50
610	190	181		1730	527	501	51
625	195	185		1790	544	517	52
640	200	190		1845	560	532	53
660	205	195		1910	578	549	54
675	210	199		1980	596	567	55
690	215	204		2050	615	584	56
705	220	209		2140	639	607	57
720	225	214			655	622	58
740	230	219			675		59
755	135	223			698		60
770	140	228			720		61
785	145	233			745		62
800	150	238	22		773		63
820	155	242	23		800		64
835	160	247	24		829		65
860	268	255	25		864		66
870	272	258	26		900		67
900	280	266	27		940		68