

CNC LATHE

ROTATING TOOL HOLDER



Global Cutting Tool manufacturer

Our aim is your success!



- | | | | |
|-----------------------|-------------------|-----------------|-----------------|
| 그리스 Greece | 베트남 Vietnam | 이란 Iran | 터키 Turkey |
| 남아프리카공화국 South Africa | 벨기에 Belgium | 이집트 Egypt | 포르투갈 Portugal |
| 네덜란드 Netherlands | 브라질 Brazil | 이탈리아 Italy | 폴란드 Poland |
| 노르웨이 Norway | 스페인 Spain | 인도 India | 프랑스 France |
| 뉴질랜드 New Zealand | 스웨덴 Sweden | 인도네시아 Indonesia | 필리핀 Philippines |
| 독일 Germany | 스위스 Switzerland | 일본 Japan | 호주 Australia |
| 덴마크 Denmark | 슬로베니아 Slovenia | 중국 China | 홍콩 Hong Kong |
| 러시아 Russia | 싱가포르 Singapore | 체코 Czech | 헝가리 Hungary |
| 말레이시아 Malaysia | 아르헨티나 Argentina | 콜롬비아 Colombia | |
| 멕시코 Mexico | 영국 United Kingdom | 캐나다 Canada | |
| 미국 U.S.A | 오스트리아 Austria | 태국 Thailand | |



인사말 / Greeting

Making customer's dreams a reality- The best mechanical solution.

(주)위딘은 1988년 7월 창업 이래 국내 초경 절삭 공구시장의 질적 향상을 위해 꾸준히 노력해오고 있습니다.

이와 같은 노력에 힘입어 국내 END MILLS, DRILLS, REAMERS, TAPS 뿐만아니라 SPECIAL TOOLS는 반도체 부품, 자동차 부품, 금형 및 공작기계 부품 등과 같은 국내 산업전반에 많은 기여를 하고 있습니다.

인화단결, 창의정신, 주인의식이라는 사훈아래 모든 임직원이 하나로 뜻을 모아 (주)위딘의 발전을 위해 땀을 흘리고, 생산되어지는 제품에 자부심을 가짐으로써 품질의 향상과 불량률 0%를 만들어 나가고 있음은 물론, 끊임없는 품질개선, 생산성 극대화, 기업의 세계화라는 경영방침아래 (주)위딘을 더욱 발전시키기 위해 최선의 노력을 아끼지 않고 있습니다.

아울러 (주)위딘 부설 연구소에서는 품질개선을 위한 끊임없는 연구를 하고 있으며, 그 결과들은 속속 품질의 향상과 신제품 개발로 나타나고 있습니다.

또한, 세계적 박람회인 EMO, JIMTOF, IMTS, SIMTOS 등의 참여 뿐만 아니라 지속적인 해외시장 개척활동으로 품질향상과 회사의 이미지 제고는 물론, 세계를 무대로 국경없는 글로벌 경영을 실현하고 있습니다.

철저한 품질관리와 정확한 납기준수는 물론 고객과 이익을 함께 나누는 자세로 업무에 임할 것을 다짐하고 당사의 축적된 경험과 노하우가 귀사의 생산성 향상과 원가절감에 기여할 수 있도록 최선을 다하겠습니다.

고객 여러분들의 꾸준한 관심과 성원에 감사드리며, 끊임없는 노력과 열정으로 임할 것을 약속드립니다.

Since its establishment in 1988, WIDIN Co.,Ltd. has been contributed to pursue the utmost customer satisfaction for the current and potential customers in the globalized market.

With continuously doing development and creativeness of the new technology through the great initiative, we, WIDIN Co.,Ltd. is always ready to response of customer needs in customer mind and eye.

To cope with the enormous, various customer demands and satisfaction from popular products to high value added products in the cutting tools industry, WIDIN Co.,Ltd. will put its best effort and will play a role of marketing initiator to lead the new 21st era by production and marketing linkage.

Aim to provide the best for money, ne tuned price, utmost quality, excellent customer services based on professionalism, all WIDIN Co.,Ltd. will promise to do its best effort at time and where it is.

Thank you.

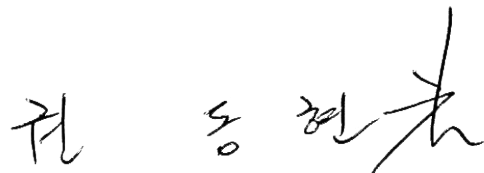

President and CEO Dong Hyun Kwon



Technology and Quality!

Quality Without Compromise

Special tool holder can be custom-made to suit customer's requirements as well as standard products.

All of parts are manufactured the thorough quality inspection.

표준품 외, 자체 설계를 바탕으로

고객맞춤형 스페셜 제품 제작이 가능합니다.

모든 부품은 철저한 품질검사를 거친 후 제작 됩니다.

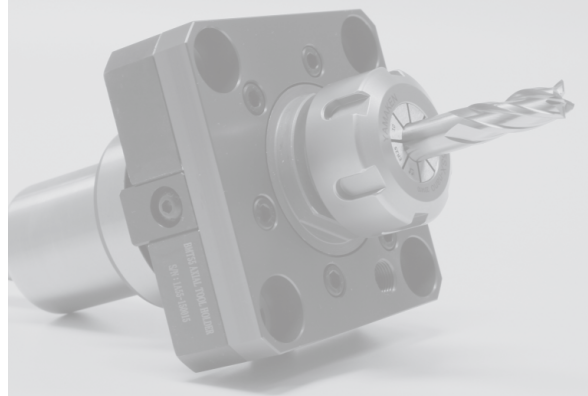
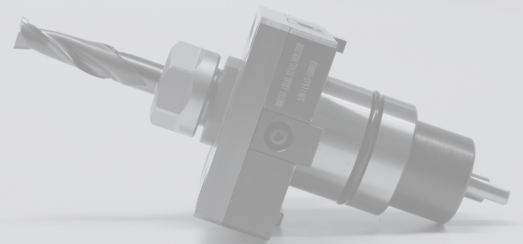

Semi-Assembly Bevel & 3D CAD Design

반조립식 베벨 & 3D CAD 디자인

Design & development experienced technical experts from the designer to the engineer, all contribute to success of development.

Different technologies are built into the smallest spec. by using the latest resources, such as 3D CAD system.

The specialist teams are networked with one another through a matrix organization and also pass on their know-how to number of trainees on regular basis.

디자인부터 설계까지 숙련된 전문가를 통해 지속적인 발전을 이루고 있습니다.

3D CAD 시스템과 같은 최신기술 도입으로 가장 작은 규격에도 용이하게 접목할 수 있습니다.

전문가들로 구성된 팀이 상호 유기적으로 소통하며 꾸준한 인재육성에 힘쓰고 있습니다.



단면도 / Sectional View ▼

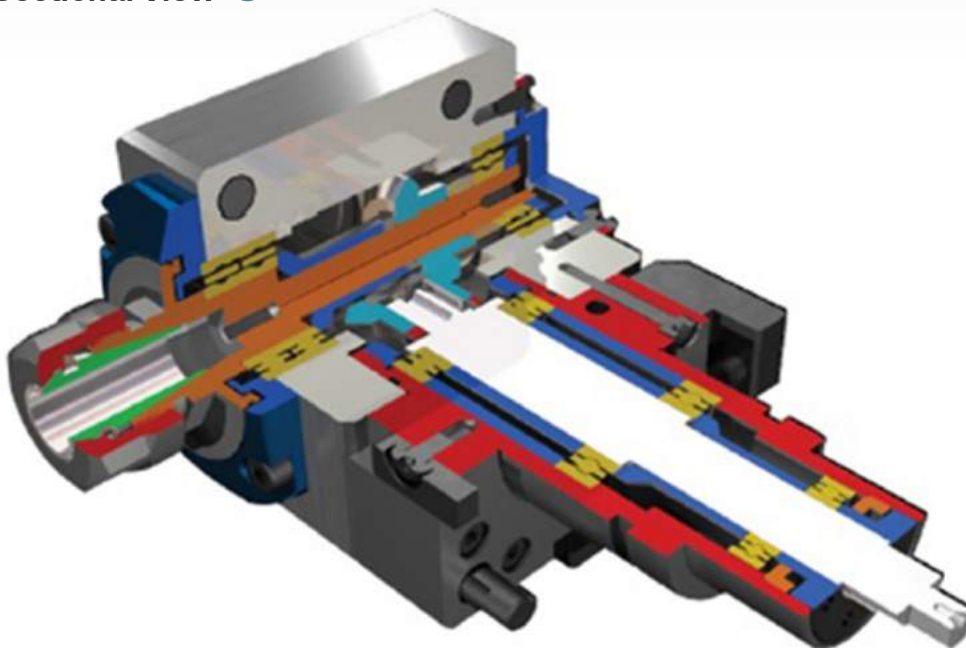



TURRET ASSEMBLY

The most competitive company WIDIN

CNC LATHE ROTATING TOOL HOLDER

Special tool holder can be custom-made to suit customer's requirements as well as standard products.

표준품 외, 자체 설계를 바탕으로 고객맞춤형 스페셜제품 제작이 가능합니다.



AXIAL ROTATING TOOL HOLDER

CNC LATHE ROTATING TOOL HOLDER



THE MOST COMPETITIVE COMPANY WIDIN
WE ARE DEVELOPED BY CONTINUED TECHNOLOGY DEVELOPMENT AND ACCUMULATION





01

- 저소음, 고강성을 위한 설계
- 발열소재를 사용한 온도 변화의 최소화
- 전용 테스트기를 이용한 장시간의 HOLDER 테스트

- Special design for Low-noise & High-rigidity.
- Use thermal material to minimize variation of accuracy.
- Every precision spindle spends long-hours on a special test bench.

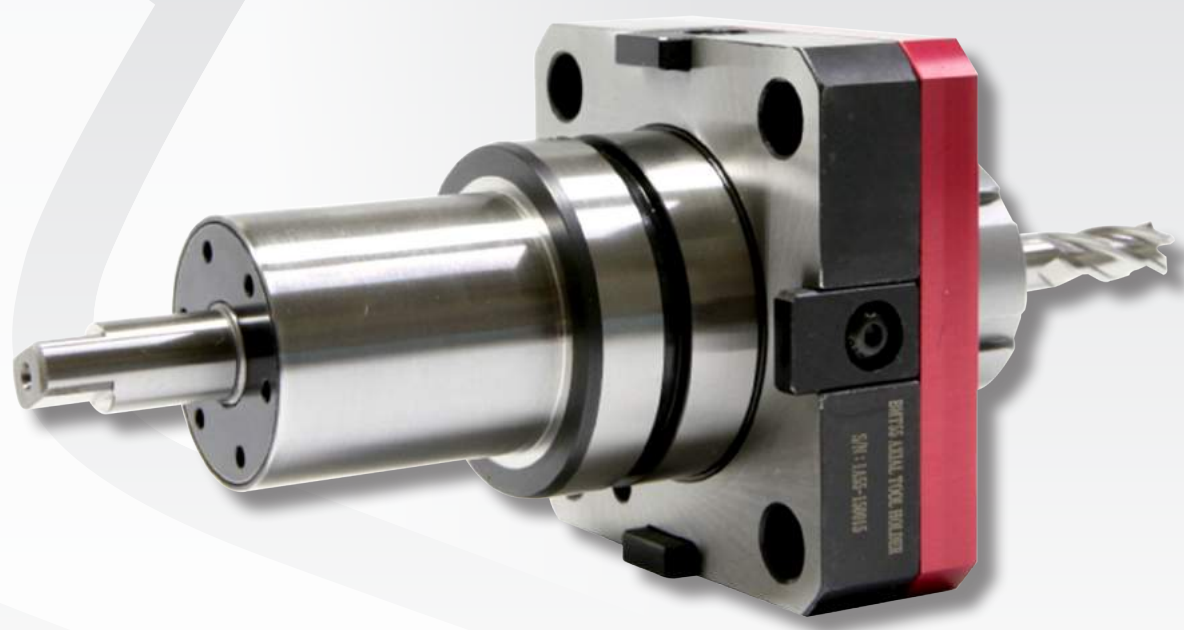
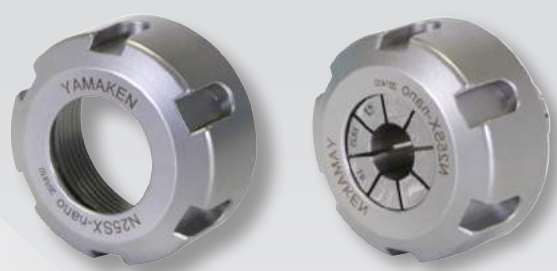

▼ 사양 / Specification

구분 / Division	항목 / Item				
Shank	BMT45	BMT55	BMT65	BMT75	BMT85
ER, ET Collet Size	20	25	32	40	50
Drill Size	1~13	1~16	2~20	3~26	10~34

RADIAL ROTATING TOOL HOLDER

CNC LATHE ROTATING TOOL HOLDER



THE MOST COMPETITIVE COMPANY WIDIN
WE ARE DEVELOPED BY CONTINUED TECHNOLOGY DEVELOPMENT AND ACCUMULATION





- 저소음, 저진동 베벨기어 사용
- 고강성 베어링 구조 설계
- 고객 맞춤형 설계 및 생산

- Use special bevel gear for Low-noise & Low-vibration.
- Special design of high-rigidity bearing structure.
- All of our productions are designed & manufactured by customer demand.



▼ 사양 / Specification

구분 / Division	항목 / Item				
Shank	BMT45	BMT55	BMT65	BMT75	BMT85
ER, ET Collet Size	20	25	32	40	50
Drill Size	1~13	1~16	2~20	3~26	10~34



ANGLE HEAD

WAN 50-40

앵글헤드

- 고성능과 정밀가공엔 아바형 앵글헤드로!
- CNC 밀링에서 범용까지 높은 활용도
- Arbor type of Angle Head for high efficiency and precision machining!
- Wide Range of CNC Machining. High performance to General Purpose

분류 Classification	코드 Code	코드설명(범례) Code Description		
		변동없음 Fixed	변수값 Parameter value	변수값 Parameter value
앵글헤드 ANGLE HEAD	WAN 50-40	WAN	50 기계측 BT50 BT50 for Machine Side	40 공구측 BT 40 BT40 for Tool Side
유니버설헤드 UNIVERSAL HEAD	WUN A-B	WUN	A 기계측 테이퍼 Taper of Machine Side	B 공구측테이퍼 Taper of Tool Side
보링헤드 BORING HEAD	WBO	WBO	-	-
틸팅헤드 TILTING HEAD	WTI A-B	WTI	A 기계측 테이퍼 Taper of Machine Side	B 공구측테이퍼 Taper of Tool Side



03

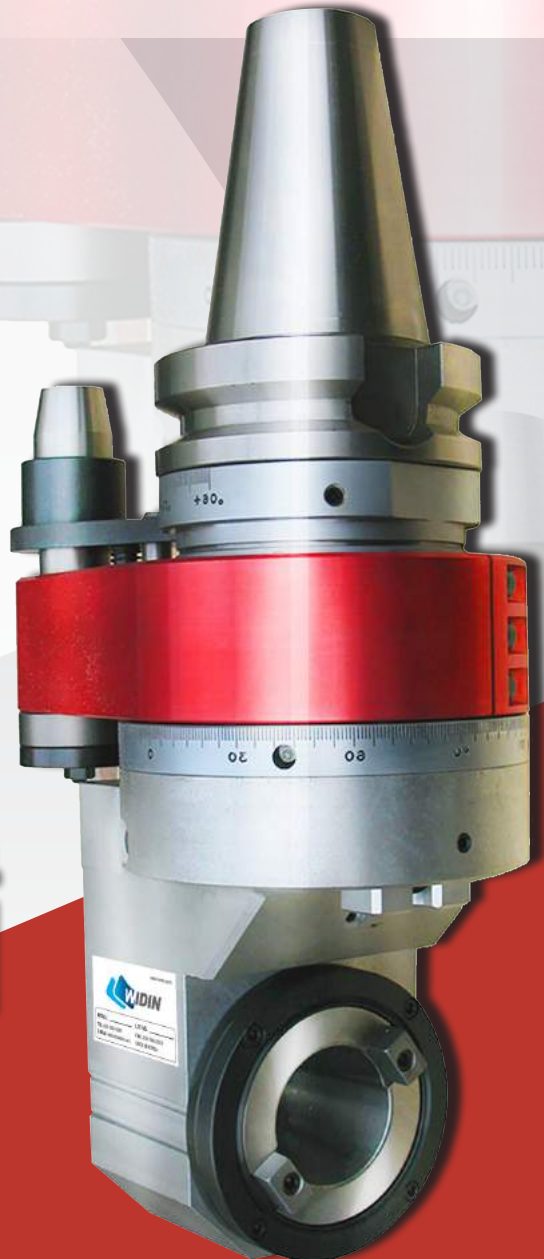

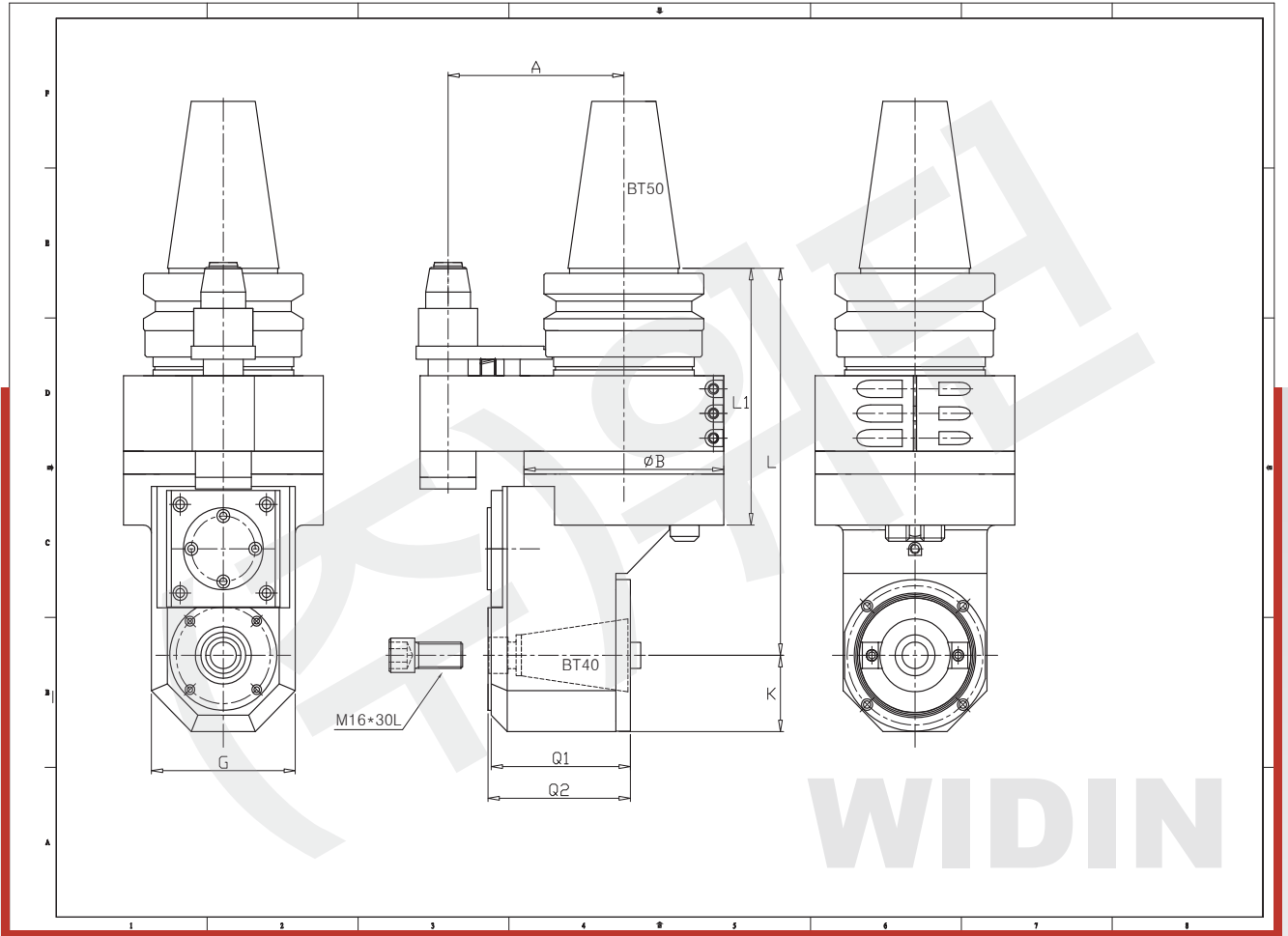

▼ 규격 / Size

WAN 50-40	L	L1	K	G	Q1	Q2	ØB	A	Tool	W(kg)
	236	156.5	46.5	90	87	89	125	110	BT40	15

▼ 생산품목 / Product List

- Angle Head / 앵글헤드
- Boring Head / 보링헤드
- Facing Head / 페이스헤드
- Special customized product
/ 특수형 주문제작

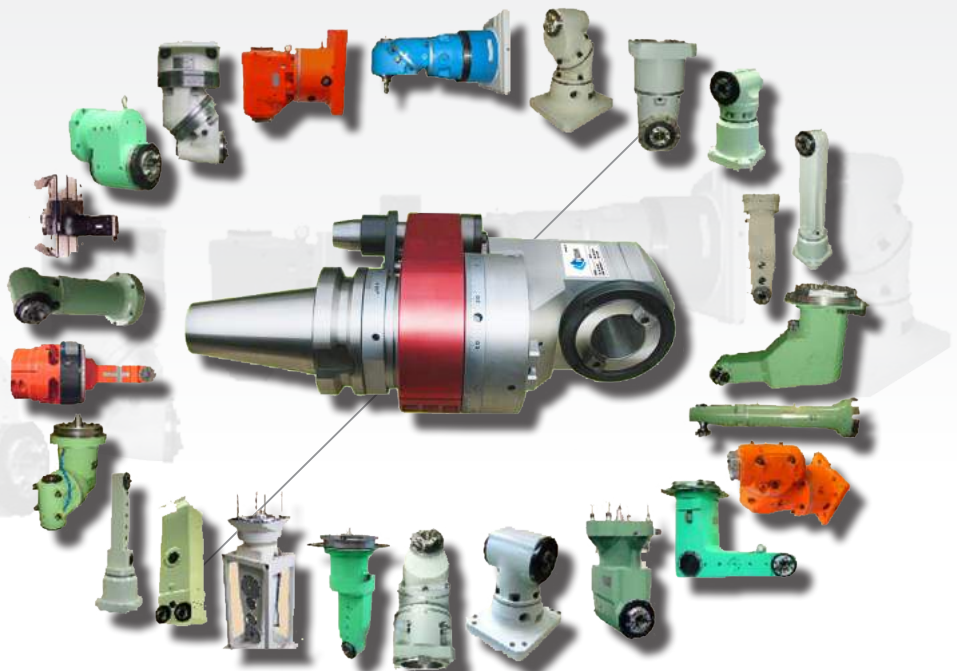



CNC FACING HEAD

WFC 50-200

CNC 페이스헤드

- 보링 머신에서도 수직 선반 가공이 가능
- 작업시간 단축, 가공비 절약, 다양한 가공작업 수행
- CNC 연동으로 정밀 형상가공과 라운드 작업 진행
- 손쉬운 작동과 첨단 자동제어 기능 탑재

- Product which can make machining in Vertical Lathe proceed in Boring Machine.
- Saving machining time, machining cost. Variable machining works.
- Best Performance with Precision process and round work.
- Easy to use and Up to date automatic control function.

분류 Classification	코드 Code	코드설명(범례) Code Description		
		변동없음 Fixed	변수값 Parameter value	변수값 Parameter value
CNC 페이스헤드 CNC FACING HEAD	WFC 50-200	WFC	50	200
		W = Widin	최소가공경 MIN Machining Dia	최대가공경 MAX Machining Dia

04



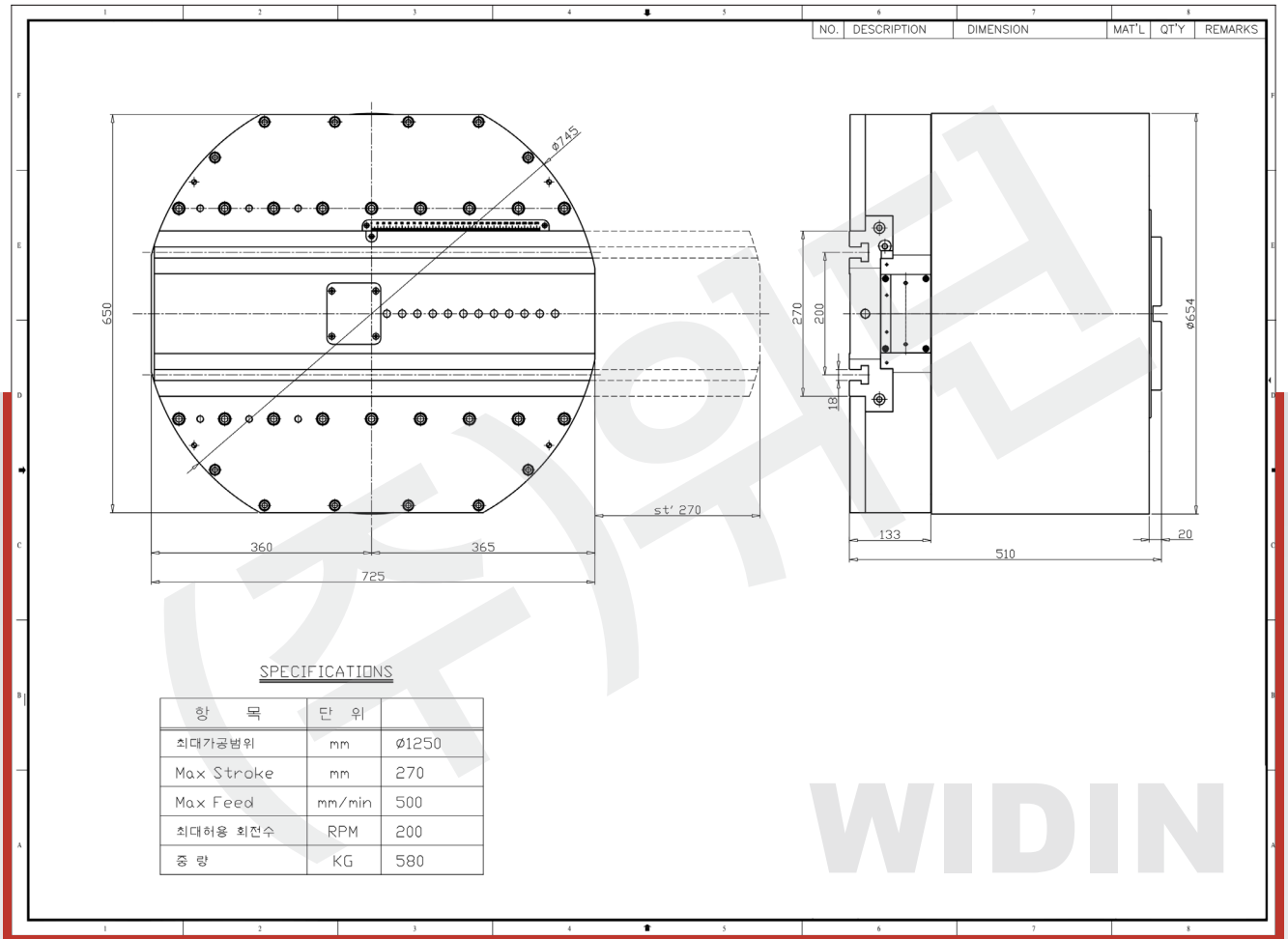

▼ 생산품목 / Product List

- Angle Head / 앵글헤드
- Boring Head / 보링헤드
- Facing Head / 페이스헤드
- Special customized product / 특수형 주문제작





CNC LATHE ROTATING TOOL HOLDER

본사 & 창원공장 경상남도 창원시 의창구 사화로 172 (팔용동) [51389]
TEL. 055-286-0905 FAX. 055-286-0978

시카고 지사 : TEL. 1-847-947-8320 / FAX. 1-847-947-8322
상하이 지사 : TEL. 86-21-5831-8103 / FAX. 86-21-5831-8153
베트남(하노이) 지사 : TEL. 84-4-6287-3839 / FAX. 84-4-6287-3828
베트남(호치민) 지사 : TEL. 84-8-2253-1117 / FAX. 84-4-6287-3828

서울 영업소 : TEL. 02-2679-0980~1 / FAX. 02-2679-0970
시화 영업소 : TEL. 031-430-5446 / FAX. 031-430-5579
대구 영업소 : TEL. 053-604-0968 / FAX. 053-604-0932
부산 영업소 : TEL. 051-319-0914 / FAX. 051-319-0976
광주 영업소 : TEL. 062-961-0985 / FAX. 062-961-0982
창원 영업소 : TEL. 055-277-9911 / FAX. 055-237-0904

Head office & Changwon Factory

172, Sahwa-ro, Uichang-gu, Changwon-si, Gyeongsangnam-do, Korea
TEL. 82-55-286-0905 FAX. 82-55-286-0978

Chicago Office(WIDIN, INC.)

1801 Hicks Rd. Unit B Rolling Meadow il 60008
TEL. 1-847-947-8320 FAX. 1-847-947-8322

Shanghai Office(WIDIN(Shanghai)Trade Co.,Ltd.)

B-901, NO 400 Pudian Road, Pudong New District, Shanghai, China
TEL. 86-21-5831-8103 FAX. 86-21-5831-8153

Vietnam Hanoi Office(WIDIN VINA Co.,Ltd.)

Room A308, 3rd floor, The Manor Tower, Me Tri Rd, My Dinh Ward, Nam Tu Liem Dist, Hanoi, Vietnam
TEL. 84-4-6287-3839 FAX. 84-4-6287-3828

Vietnam Ho Chi Minh Office(WIDIN VINA Co.,Ltd.)

Room 402, Ben Thanh Tourist Building 1, 79 Nguyen Trai St., Ben Thanh Ward, HCMC, Vietnam
TEL. 84-4-6287-3839 FAX. 84-4-6287-3828